



## REHAU HEAT-SHRINK PRODUCTS

# REHAU HEAT-SHRINK PRODUCTS

## CONTENTS

---

Polymers perfected .....	3
List of types .....	6
Heat-shrink sleeves made from crosslinked polymers .....	7
Processing tips for RAUCROSS heat-shrink sleeves .....	9
Chemical resistance of RAU-VPE .....	10
RAUCROSS heat-shrink sleeves .....	12
Heat-shrink sleeves made from RAU-PVC soft .....	58
Processing tips for heat-shrink sleeves made from RAU-PVC soft .....	59
Chemical resistance of RAU-PVC soft .....	60
Heat-shrink sleeves made from RAU-PVC smooth .....	64
Heat-shrink sleeves made from RAU-PVC ribbed .....	66
Enquiry checklist RAUCROSS heat-shrink sleeves .....	69
Enquiry checklist RAUCROSS heat-shrink sleeves made from RAU-PVC .....	70

# REHAU HEAT-SHRINK PRODUCTS

POLYMERS PERFECTED - WE KNOW HOW

---

**REHAU has been processing polymer materials for decades and serves various sector segments with these.**

The know-how gathered and the permanent orientation to customer requirements identify REHAU as a specialist in the area of hose, silicone, profile and moulding technology.

Already in the area of heat-shrink products the strictest requirements of our quality assurance systems as well as international standards and user specifications are consistently monitored and adhered to.

**We are always striving to fulfil your requirements.**



---

Due to a system conversion to SAP in 2012, our article numbers have changed to material numbers.

The previous article numbers have become material numbers with 1 extra digit:

old:        123456     (article number)

new:       1123456     (material number)

To illustrate this, we have visually identified the additional digits:

**1** = 1, e.g.: **1**123456

Please note that in the system all quotations, order confirmations, dispatch notes and invoices will largely only be issued with the 7-digit number.

---

# REHAU HEAT-SHRINK PRODUCTS

POLYMERS PERFECTED - WE KNOW HOW

For you this means:  
Capability in all phases of product development and supply.

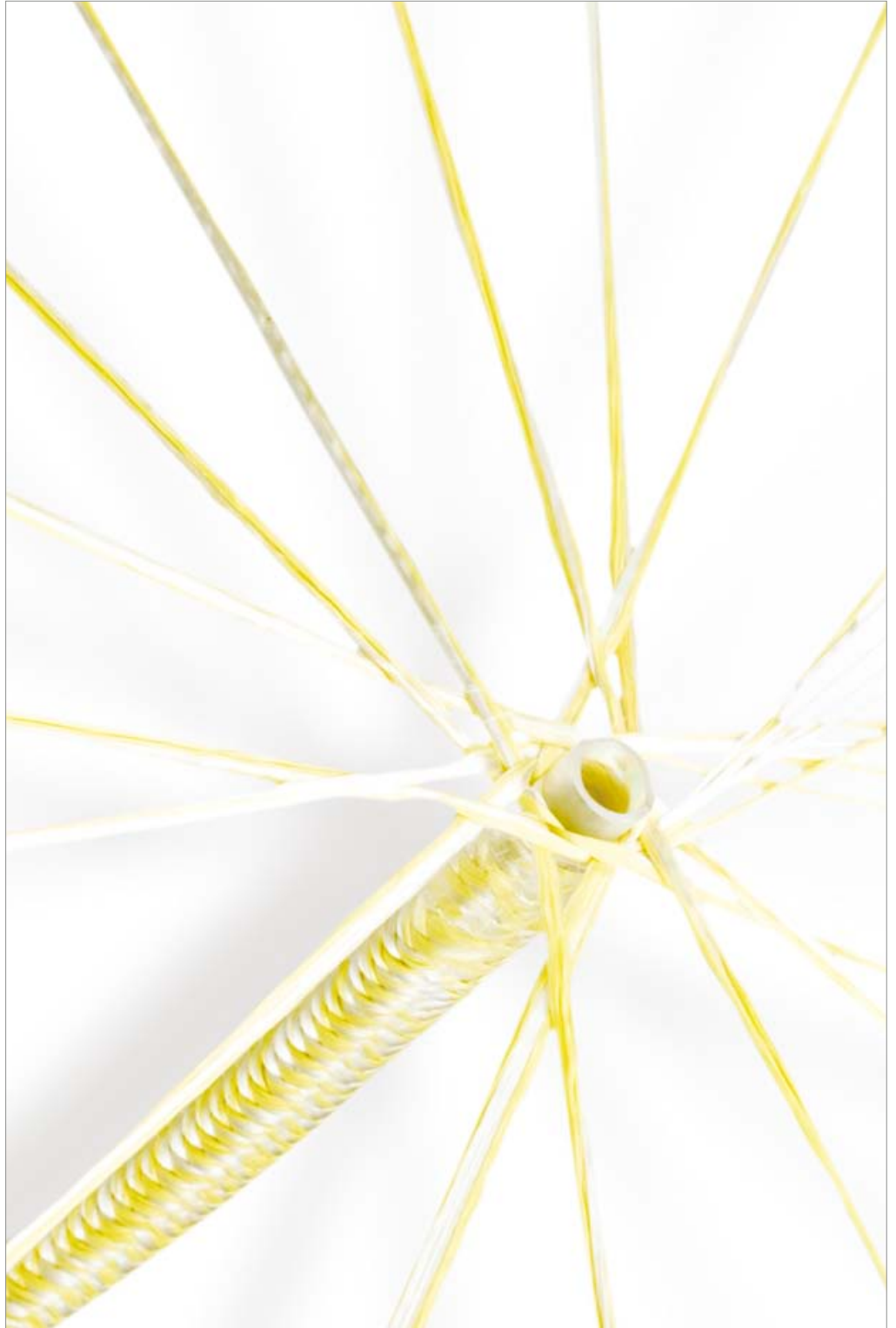

# REHAU HEAT-SHRINK PRODUCTS

The following pictograms describe the main attributes of the RAUCROSS heat-shrink sleeve product range.



Flame-retardant



Shrink rate



Shrink temperature



Permanent heat resistance



Not flame-retardant



ELV End-of-life vehicle directive



RoHS (= Restriction of the Use of Certain Hazardous Substances in Electrical and Electronic Equipment)

## Sleeve dimensions:

The information in the measurement chart is based on the following dimensional parameters.

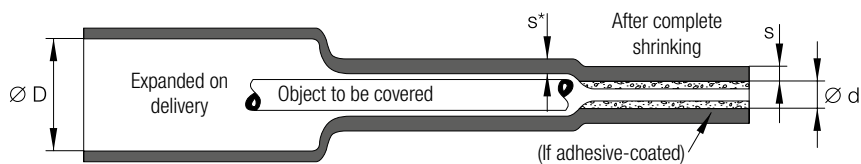

# REHAU HEAT-SHRINK PRODUCTS

## LIST OF TYPES

### Thin-walled heat-shrink sleeves made from RAU-VPE

<b>RAUCROSS DS</b>	Flame-retardant heat-shrink sleeve for universal application
<b>RAUCROSS Box</b>	Small rolls in a dispenser box
<b>RAUCROSS Assortment</b>	Practical assortment of heat-shrink sleeves
<b>RAUCROSS DSN</b>	Self-extinguishing quality with UL approval
<b>RAUCROSS DSNG</b>	Yellow and green striped
<b>RAUCROSS DS 3/DS 4</b>	Flame-retardant quality with a shrink rate 3:1 or 4:1
<b>RAUCROSS DON</b>	Transparent
<b>RAUCROSS DO</b>	Low-cost, halogen-free heat-shrink sleeve
<b>RAUCROSS DSTT</b>	Quick shrinking
<b>RAUCROSS DSHF</b>	Halogen-free and self-extinguishing
<b>RAUCROSS DSC</b>	Inserted into tight radii without creasing
<b>RAUCROSS DOA</b>	Weathering and ageing-resistant
<b>RAUCROSS DOU</b>	Heat-shrink sleeve as a cover for fluorescent pipes

### Thin-walled heat-shrink sleeves made from RAU-VPE, with adhesive

<b>RAUCROSS DSNK 3/DSNK 4</b>	Heat-shrink sleeve with an adhesive coating shrink rate 3:1 or 4:1
<b>RAUCROSS DSNK Box</b>	DSNK 3, Small rolls in a dispenser box

### Medium and thick-walled heat-shrink sleeves made from RAU-VPE

<b>RAUCROSS MO(K)</b>	Medium-walled heat-shrink sleeve with/without hot-melt adhesive
<b>RAUCROSS WS(K)</b>	Thick-walled heat-shrink sleeve with/without hot-melt adhesive
<b>RAUCROSS WSK 6</b>	Thick-walled heat-shrink sleeve with hot-melt adhesive and high shrink rate

### Heat-shrink sleeves made from fluoroplastics, fluoroelastomers and elastomers

<b>RAUCROSS PVDF</b>	Transparent, self-extinguishing (Kynar®) heat-shrink sleeve
<b>RAUCROSS DSV</b>	Heat-shrink sleeve with outstanding chemical resistance (Viton®)
<b>RAUCROSS DSDR</b>	Very flexible elastomer heat-shrink sleeve (oil and fuel resistant)

### Heat-shrink end caps made from RAU-VPE

<b>RAUCROSS SKE</b>	Adhesive-coated end caps
<b>RAUCROSS SKE-V</b>	Adhesive-coated end caps with valve

### Heat-shrink sleeves made from PVC

<b>PVC 9200</b>	Fully coloured, self-extinguishing
<b>PVC 9205</b>	UV-stabilised, self-extinguishing
<b>PVC 9210</b>	Transparent, self-extinguishing

# REHAU HEAT-SHRINK PRODUCTS

HEAT-SHRINK SLEEVES MADE FROM CROSSLINKED POLYMERS

---



# REHAU HEAT-SHRINK PRODUCTS

## HEAT-SHRINK SLEEVES MADE FROM CROSSLINKED POLYMERS

---

RAUCROSS heat-shrink sleeves are produced from crosslinked, specially modified polymers. Due to the crosslinking, these polymers are non-melting, cold flow-resistant and heat-shrinkable.

Due to the outstanding insulation properties, the excellent mechanical and thermal behaviour and the simple, straightforward application, RAUCROSS heat-shrink sleeves are suitable for a wide range of applications.

All of the products listed are exclusively designed for the low voltage range up to 1 kV.

REHAU offers a variety of **standard product ranges** made from crosslinked polyolefins (RAU-VPE) in a wide range of dimensions, qualities, wall thicknesses and colours. Rolls for industrial processing and also practical trade packs and assortments are available from stock.

RAUCROSS sleeves shrink to at least 50 % of their supply diameter. Some types offer much **larger shrink rates**, are therefore easy to use and are even suitable for components with large diameter variations.

To seal against moisture and environmental influences (preferably not to improve adhesion) RAUCROSS heat-shrink sleeves with **internal adhesive coating** as well as anti-corrosion compound are available in various standard colours including transparent. As a result of this, covered cable connections and markings remain visible for example.

REHAU offers **application-specific solutions** for components with complicated shapes, e.g. in the case of very pronounced variations in cross-section or narrow bends.

If you cannot find a suitable heat-shrink sleeve in our product range right away, our **technical applications department** is there at any time to provide advice.

You will find product range overviews including material data sheets on the REHAU home page [www.rehau.de](http://www.rehau.de).



# REHAU HEAT-SHRINK PRODUCTS

## PROCESSING TIPS FOR RAUCROSS HEAT-SHRINK SLEEVES

---

Special knowledge and tools are not required for processing. The temperature required for the shrinking process can be achieved with hot air blowers, a drying oven, a shrink tunnel, an infrared radiator, an open gas flame, etc.

### **Shrink range**

RAUCROSS heat-shrink sleeves generally shrink when heated to a temperature above approx. 120 °C to at least 50 % of the supply diameter. However, logically the shrink temperature should be higher, e.g. 180 °C (depending on the object and process).

Economic shrink temperatures are at around 200 °C.

Various basic conditions form part of the shrinking procedure, e.g. shape and size of the object, surface quality, material, etc.

This influence must also be taken into account, in the same way as the usual longitudinal shrinkage for heat-shrink sleeves of between +5 and -10 % (somewhat more for sleeves with adhesive).

The exact sleeve length should therefore be established beforehand by way of test shrinking; preferably under the exact conditions that will be used in the individual case during the planned production.

Rolls may contain several part lengths.

### **Preparation**

- Cut edges should be straight and free of notches
- Surfaces to be covered should be clean and grease-free
- Larger items (especially metals) should be pre-heated
- Pretreatment is required for adhesive-coated sleeves (e.g. flaming for PE cable sheathing)

### **Shrinking process**

The sleeving should be evenly heated all over during shrinking in order to avoid overheating in places. The shrinking process ends as soon as the sleeve lies flat without creasing or the adhesive is visible at the end of the sleeve. It is recommended that the room is ventilated sufficiently during shrinking.

### **Storage**

We recommend that RAUCROSS products are stored at below +40 °C in dry conditions out of sunlight and are processed within six months.

# REHAU HEAT-SHRINK PRODUCTS

## CHEMICAL RESISTANCE OF RAU-VPE

The changes to the properties of plastics in contact with chemicals primarily concern physical processes, e.g. swelling or dissolving of the polymer. RAUCROSS heat-shrink sleeves, made from crosslinked polyethylene (RAU-VPE), behave more favourably than non-crosslinked PE types due to the chemical linking of the polymer chains. To evaluate the resistance, the change to the tensile and ductile behaviour during storage in appropriate substances without the additional effect of

mechanical forces was used as a basis. The chemical resistance listed here generally cannot be applied to every RAUCROSS heat-shrink sleeve, because e.g. the formulation used and the level of crosslinking have a not inconsiderable influence. We therefore recommend testing under the exact practical conditions and that you contact our technical applications department.

Substance	20 °C	60 °C
Acetone	+	
Acrylonitrile	+	+
Ethyl acetate	+	•
Ethyl alcohol	+	+
Ethyl glycol	+	+
Allyl alcohol	+	•
Aluminium chloride, anhydrous	+	+
Aluminium sulphate, aqueous	+	+
Formic acid	+	+
Ammonia, aqueous	+	+
Ammonium chloride, aqueous	+	+
Ammonium sulphate, aqueous	+	+
Aniline, pure	+	+
Petrol	+	•
Benzene	•	+
Benzoic acid, aqueous	+	+
Bitumen	+	+
Beer	+	+
Bleaching solution	+	
Bromine	-	-
Butanol	+	+
Butter	+	+
Butyric acid	+	•
Butyl acetate	+	•
Butandiol	+	+
Chlorine water	-	-
Chlorine gas, moist	•	-
Chloroform	•	-
Chromic acid 50 %	+	-
Chromic acid/sulphuric acid	+	-

Substance	20 °C	60 °C
Cyclohexane	+	•
Cyclohexanol	+	+
Cyclohexanone	+	•
Decalin	+	-
Dibutyl ether	•	
Dibutyl phthalate	+	•
Dichloroethylene	•	-
Dichlorobenzene	•	-
Engine oil	+	•
Detergents, synthetic	+	+
Acetic acid	+	+
Esters, aliphatic	+	•
Esters, aromatic	•	•
Fluorine	-	-
Hydrofluoric acid	+	•
Formaldehyde (40 %)	+	+
Glycols	+	+
Glycerine	+	+
Heating oil	+	•
Hexane	+	+
Iodine tincture	+	•
Potassium bichromate, 40 %	+	+
Potassium chloride, aqueous	+	+
Potassium hydroxide, 30 % solution	+	+
Potassium permanganate (20 % solution)	+	+
Aqua regia	-	-
Carbon dioxide	+	+
Cresols	+	•
Linseed oil	+	+
Cod liver oil	+	+

Key: + = resistance • = limited resistance - = not resistant

# REHAU HEAT-SHRINK PRODUCTS

## CHEMICAL RESISTANCE OF RAU-VPE

Substance	20 °C	60 °C
Magnesium salts, aqueous	+	+
Maleic acid	+	+
Methyl ethyl ketone	+	•
Methanol	+	+
Methylene chloride	•	-
Milk	+	+
Engine oil	+	•
Naphtha	+	•
Naphthalene	+	-
Sodium hypochlorite	+	•
Nitrobenzene	+	•
Sodium hydroxide	+	+
Oleum	-	-
Oils, essential	+	•
Oils, vegetable	+	•
Oxalic acid, 50%	+	+
Ozone, aqueous <0.1%	+	-
Paraffin oil	+	+
Petroleum ether	+	
Petroleum	+	•
Pesticides	+	+
Phenol	+	•
Phosphates, aqueous	+	+
Phosphoric acid, 95 %	+	+
Phthalic acid, 50 %	+	+
Polyglycols	+	+
Propionic acid, 50 %	+	+
Propanol	+	+
Propyl alcohol	+	+
Pyridine	+	•

Substance	20 °C	60 °C
Mercury	+	+
Nitric acid, 30 %	+	+
Nitric acid, 50 %	•	-
Hydrochloric acid, conc.	+	+
Sulphuric acid, up to 50 %	+	+
Sulphuric acid, 98 %	•	-
Sulphur trioxide	-	-
Hydrogen sulphide	+	+
Soap solution	+	+
Silicone oil	+	+
Styrene	•	-
Turpentine oil	+	•
Carbon tetrachloride	•	-
Tetrahydrofuran	•	-
Tetralin	+	•
Toluene	•	-
Trichlorethylene	•	-
Transformer oil	+	•
Vaseline	+	•
Water	+	+
Hydrogen peroxide, 30%	+	+
Hydrogen peroxide, 100 %	+	-
Wine	+	+
Detergent	+	+
Xylene	•	-
Citric acid	+	+

Key: + = resistance • = limited resistance - = not resistant

# RAUCROSS® DS

## THE FLAME-RETARDANT STANDARD HEAT-SHRINK SLEEVE

For universal application, flexible RAUCROSS heat-shrink sleeve, flame-retardant

For insulation, marking, bundling and processing cable sets and connections



2 : 1



> 90 °C to 200 °C



+135 °C  
-55 °C

### Material:

Crosslinked, modified polyolefin

### Standard colours:

Black	98001
White	91017
Red	95025
Blue	97032
Yellow	93035



### Measurement chart: RAUCROSS DS

Mat. No.	Dim. D inches	Internal diameter (mm)		Wall thickness fully recovered s	Rolls		Packaging unit black
		min. as supplied D	Max. fully recovered d		black	coloured	
1082321	3/64	1.2	0.6	0.4	300 m	150 m	3000 m
1082331	1/16	1.6	0.8	0.4	300 m	150 m	3000 m
1081881	3/32	2.4	1.2	0.5	300 m	150 m	3000 m
1081891	1/8	3.2	1.6	0.5	300 m	150 m	1500 m
1081821	3/16	4.8	2.4	0.5	300 m	75 m	900 m
1081831	1/4	6.4	3.2	0.6	300 m	75 m	600 m
1081901	3/8	9.5	4.8	0.6	150 m	75 m	300 m
1081911	1/2	12.7	6.4	0.6	100 m	50 m	700 m
1081632	5/8	16.0	8.0	0.6	100 m	50 m	700 m
1081921	3/4	19.0	9.5	0.8	50 m	30 m	350 m
1081931	1	25.4	12.7	0.9	50 m	30 m	250 m
1081642	1 1/4	32.0	16.0	0.9	50 m	30 m	250 m
1082341	1 1/2	38.0	19.0	1.0	50 m	30 m	150 m
1082351	2	51.0	25.4	1.1	50 m	30 m	150 m
1080522	3	76.0	38.0	1.3	25 m	15 m	50 m
1261441	4	102.0	51.0	1.4	25 m	15 m	50 m
1201583	5	125.0	62.5	1.5	15 m	15 m	30 m
1201588	6	151.0	76.0	1.5	15 m	15 m	30 m

# RAUCROSS® DS

## THE FLAME-RETARDANT STANDARD HEAT-SHRINK SLEEVE

**For universal application, flexible RAUCROSS heat-shrink sleeve, flame-retardant**

For insulation, marking, bundling and processing cable sets and connections

### Technical values

Properties	Test method	RAU-VPE 142 (Crosslinked, modified polyolefin)
<b>Physical:</b>		
Tensile strength	DIN-EN-ISO 527/1-3	13 N/mm <sup>2</sup>
Elongation at break	DIN-EN-ISO 527/1-3	350 %
Change in length during shrinking	ASTM D 2671	±5 %
Water absorption	DIN 53495-1	< 0.2 %
Spec. weight	DIN 53479	1.45 g/cm <sup>3</sup>
<b>Thermal:</b>		
Permanent heat resistance		-55 °C to +135 °C short-term: up to +200 °C
Shrink temperature		> 90 °C
Thermal shock (4 h at 200 °C)	ASTM D 2671	No dropping and flowing, no formation of cracks
Thermal ageing (168 h at 175 °C)	ASTM D 2671	
Elongation at break		> 200 %
Flexibility in cold conditions (-55 °C)	ASTM D 2671	No formation of cracks
Burning behaviour	UL 224	Flame-retardant
<b>Chemical:</b>		
Solvent resistance		Good
Copper tolerance	ASTM D 2671	Non-corrosive
<b>Electrical:</b>		
Dielectric strength	ASTM D 2671	20 kV/mm
Volume resistivity	ASTM D 257	10 <sup>14</sup> Ω cm

# RAUCROSS® BOX

## HEAT-SHRINK SLEEVE BOX

### RAUCROSS heat-shrink sleeve box, practical small rolls in a dispenser box

- Rapid shrinking
- Easy to dispense
- Leftover quantities remain protected



2 : 1



> 90 °C to 200 °C



+135 °C  
-55 °C

#### Material:

Crosslinked, modified polyolefin

#### Standard colours::

Black	98001
White	91017
Red	95025
Blue	97032
Yellow	93035
Yellow/Green	93035/99027



### Measurement chart: Heat-shrink sleeves 2:1

Mat. No	Dim. D inches	Internal diameter (mm)		Wall thickness fully recovered s	Contents per box
		min. as supplied D	Max. fully recovered d		
1 254539	3/32	2.4	1.2	0.5	15 m
1 254549	1/8	3.2	1.6	0.5	15 m
1 254559	3/16	4.8	2.4	0.5	12 m
1 254569	1/4	6.4	3.2	0.6	12 m
1 254579	3/8	9.5	4.8	0.6	8 m
1 254589	1/2	12.7	6.4	0.6	8 m
1 254599	3/4	19.0	9.5	0.8	5 m
1 254609	1	25.4	12.7	0.9	5 m

# RAUCROSS® BOX

## HEAT-SHRINK SLEEVE BOX

### RAUCROSS heat-shrink sleeve box, practical small rolls in a dispenser box

- Rapid shrinking
- Easy to dispense
- Leftover quantities remain protected

#### Technical values

Properties	Test method	RAU-VPE 142 (Crosslinked, modified polyolefin)
<b>Physical:</b>		
Tensile strength	DIN-EN-ISO 527/1-3	13 N/mm <sup>2</sup>
Elongation at break	DIN-EN-ISO 527/1-3	350 %
Change in length during shrinking	ASTM D 2671	±5 %
Water absorption	DIN 53495-1	< 0.2 %
Spec. weight	DIN 53479	1.45 g/cm <sup>3</sup>
<b>Thermal:</b>		
Permanent heat resistance		-55 °C to +135 °C short-term: up to +200 °C
Shrink temperature		> 90 °C
Thermal shock (4 h at 200 °C)	ASTM D 2671	No dropping and flowing, no formation of cracks
Thermal ageing (168 h at 175 °C)	ASTM D 2671	
Elongation at break		> 200 %
Flexibility in cold conditions (-55 °C)	ASTM D 2671	No formation of cracks
Burning behaviour	UL 224	Flame-retardant
<b>Chemical:</b>		
Solvent resistance		Good
Copper tolerance	ASTM D 2671	Non-corrosive
<b>Electrical:</b>		
Dielectric strength	ASTM D 2671	> 20 kV/mm
Volume resistivity	ASTM D 257	10 <sup>14</sup> Ω cm

# RAUCROSS® DS ASSORTMENTS

## PRACTICAL ASSORTMENTS

### Practical assortments of heat-shrink sleeves for the trade and craftsmen in 2 sizes:

- Assortment S - black
- Assortment M - assorted colours

Quality: RAUCROSS DS



2 : 1



> 90 °C to 200 °C



+135 °C  
-55 °C

#### Material:

Crosslinked, modified polyolefin

#### Colours included (assortment M):

Black  
White  
Red  
Blue  
Yellow  
Transparent  
Yellow/Green



### Contents: Assortment of coloured heat-shrink sleeve sections in the following dimensions:

Internal diameter (mm)		Assortment S	Assortment M
min. as supplied D	Max. fully recovered d	Mat. No <b>1</b> 267490	Mat. No <b>1</b> 261795
1.6	0.8	x	x
2.4	1.2	x	x
3.2	1.6	x	x
4.8	2.4	x	x
6.4	3.2	x	x
9.5	4.8	x	x
12.7	6.4	x	x
19	9.5	-	x
Contents approx.:		125 sections (black)	230 sections (coloured)



# RAUCROSS® DS ASSORTMENTS

## PRACTICAL ASSORTMENTS

### Practical assortments of heat-shrink sleeves for the trade and craftsmen in 2 sizes:

- Assortment S - black
  - Assortment M - assorted colours
- Quality: RAUCROSS DS

#### Technical values

Properties	Test method	RAU-VPE 142 (Crosslinked, modified polyolefin)
<b>Physical:</b>		
Tensile strength	DIN-EN-ISO 527/1-3	> 13 N/mm <sup>2</sup>
Elongation at break	DIN-EN-ISO 527/1-3	> 350 %
Change in length during shrinking	ASTM D 2671	+5 % to -10 %
Water absorption	DIN 53495-1	< 0.2 %
Spec. weight	DIN 53479	1.45 g/cm <sup>3</sup>
<b>Thermal:</b>		
Permanent heat resistance		-55 °C to +135 °C short-term: up to +200 °C
Shrink temperature		> 90 °C
Thermal shock (4 h at 200 °C)	ASTM D 2671	No dropping, flowing, no formation of cracks
Thermal ageing (168 h at 175 °C)	ASTM D 2671	
Elongation at break		> 200 %
Flexibility in cold conditions (-55 °C)	ASTM D 2671	No formation of cracks
Burning behaviour	MVSS 302	Flame-retardant
<b>Chemical:</b>		
Solvent resistance		Good
Copper tolerance	ASTM D 2671	Non-corrosive
<b>Electrical:</b>		
Dielectric strength	ASTM D 2671	20 kV/mm
Volume resistivity	ASTM D 257	10 <sup>14</sup> Ω cm

# RAUCROSS® DSN

## SELF-EXTINGUISHING

### Self-extinguishing, flexible RAUCROSS heat-shrink sleeve with UL approval

- UL 224, 125 °C, VW1
- CSA C22.2 No. 198.1, OFT
- DIN EN 60684-3-211
- SAE-AMS-DTL-23053/5 class 3



to 2 : 1



> 100 °C to 200 °C



+135 °C  
-55 °C

#### Material:

Crosslinked, modified polyolefin

#### Standard colours::

Black	98001
White	91017
Red	95043
Blue	97050
Yellow	93035



### Measurement chart: RAUCROSS DSN

Mat. No	Dim. D inches	Internal diameter (mm)		Max. fully recovered d	Wall thickness fully recovered s	Rolls
		min. as supplied D	Max. fully recovered d			
1083171	3/64	1.2	0.6	0.4	300 m	
1083181	1/16	1.6	0.8	0.4	300 m	
1083191	3/32	2.4	1.2	0.5	300 m	
1083201	1/8	3.2	1.6	0.5	300 m	
1083211	3/16	4.8	2.4	0.5	300 m	
1083221	1/4	6.4	3.2	0.6	300 m	
1083231	3/8	9.5	4.8	0.6	150 m	
1083241	1/2	12.7	6.4	0.6	100 m	
1083251	3/4	19.0	9.5	0.8	50 m	
1083261	1	25.4	12.7	0.9	50 m	
1083271	1 1/2	38.0	19.0	1.0	50 m	
1083281	2	51.0	25.4	1.1	50 m	
1253765	3	76.0	38.0	1.3	25 m	
1253775	4	102.0	51.0	1.4	25 m	

# RAUCROSS® DSN

## SELF-EXTINGUISHING

### Self-extinguishing, flexible RAUCROSS heat-shrink sleeve with UL approval

- UL 224, 125 °C, VW1
- CSA C22.2 No. 198.1, OFT
- DIN EN 60684-3-211
- SAE-AMS-DTL-23053/5 class 3

### Technical values

Properties	Test method	RAU-VPE 1422 (Crosslinked, modified polyolefin)
------------	-------------	---

#### Physical:

Tensile strength	ASTM D 638	13 N/mm <sup>2</sup>
Elongation at break	ASTM D 638	300 %
Change in length during shrinking	ASTM D 2671	±5 %
Water absorption	DIN 53495-1	< 0.2 %
Spec. weight	DIN 53479	1.45 g/cm <sup>3</sup> (colours)

#### Thermal:

Permanent heat resistance		-55 °C to +135 °C short-term: up to +200 °C
Shrink temperature		> 100 °C
Thermal shock (4 h at 250 °C)	ASTM D 2671	No dropping and flowing, no formation of cracks
Thermal ageing (168 h at 150 °C)	ASTM D 2671	Elongation at break > 200 %
Flexibility in cold conditions (-55 °C)	ASTM D 2671	No formation of cracks
Burning behaviour	UL 224 VW 1	Passed

#### Chemical:

Solvent resistance		Good
Copper tolerance	ASTM D 2671	Non-corrosive

#### Electrical:

Dielectric strength	ASTM D 2671	20 kV/mm
Volume resistivity	ASTM D 257	10 <sup>14</sup> Ω cm

# RAUCROSS® DSNG

## YELLOW AND GREEN STRIPED

### Yellow and green striped RAUCROSS heat-shrink sleeve for marking ground wires

- to MIL-I-23053/5 class 3
- self-extinguishing to UL 224



to 2 : 1



> 115 °C to 200 °C



+135 °C  
-55 °C

#### Material:

Crosslinked, modified polyolefin

#### Standard colours::

Yellow and green striped  
93035/99027

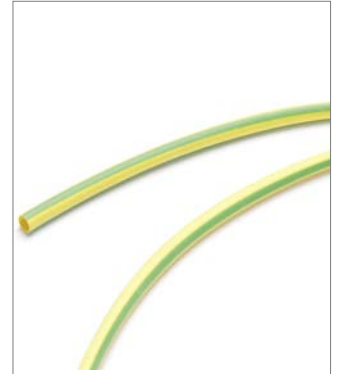

### Measurement chart: RAUCROSS DSNG

Mat. No	Dim. D inches	Internal diameter (mm)		Wall thickness fully recovered s	Rolls
		min. as supplied D	Max. fully recovered d		
1 253785	1/8	3.2	1.6	0.5	150 m*
1 253795	3/16	4.8	2.4	0.5	75 m*
1 253805	1/4	6.4	3.2	0.6	75 m*
1 253815	3/8	9.5	4.8	0.6	75 m*
1 253825	1/2	12.7	6.4	0.6	50 m*
1 253835	3/4	19.0	9.5	0.8	30 m*
1 253845	1	25.4	12.7	0.9	30 m*
1 253855	1 1/2	38.0	19.0	1.0	30 m

\* Also available in small rolls in a dispenser box (see Page 14)

# RAUCROSS® DSNG

## YELLOW AND GREEN STRIPED

### Yellow and green striped RAUCROSS heat-shrink sleeve for marking ground wires

- to MIL-I-23053/5 class 3
- self-extinguishing to UL 224

#### Technical values

Properties	Test method	RAU-VPE 142 (Crosslinked, modified polyolefin)
<b>Physical:</b>		
Tensile strength	ASTM D 638	15 N/mm <sup>2</sup>
Elongation at break	ASTM D 638	400 %
Change in length during shrinking	ASTM D 2671	±10 %
Water absorption	DIN 53495-1	< 0.2 %
Spec. weight	DIN 53479	1.28 g/cm <sup>3</sup>
<b>Thermal:</b>		
Permanent heat resistance		-55 °C to +135 °C short-term: up to +200 °C
Shrink temperature		> 115 °C
Thermal shock (4 h at 200 °C)	ASTM D 2671	No dropping and flowing, no formation of cracks
Thermal ageing (168 h at 158 °C)	ASTM D 2671	
Elongation at break		> 300 %
Flexibility in cold conditions (4h at -55 °C)	ASTM D 2671	No formation of cracks
Burning behaviour	UL 224	Passed
<b>Chemical:</b>		
Solvent resistance		Good
<b>Electrical:</b>		
Dielectric strength	VDE 303-21	20 kV/mm

# RAUCROSS® DS 3

## HIGH SHRINK RATE

Flame-retardant RAUCROSS heat-shrink sleeve, for components with large variations in diameter, to SAE-AMS-DTL-23053/5 class 1



to 3 : 1



> 90 °C to 200 °C



+135 °C  
-55 °C

### Material:

Crosslinked, modified polyolefin

### Standard colours::

Black 98001

White 91017

Red 95025

Blue 97032

Yellow 93035

Transparent 90003

(not flame-retardant)



### Measurement chart: RAUCROSS DS 3

Mat. No	Internal diameter (mm)		Wall thickness fully recovered s	Rolls
	min. as supplied D	Max. fully recovered d		
1 259046	1.5	0.5	0.5	300 m
1 259056	3.0	1.0	0.6	300 m
1 260350	4.8	1.6	0.6	300 m
1 259066	6.0	2.0	0.7	300 m
1 259076	9.0	3.0	0.8	150 m
1 259086	12.0	4.0	0.8	100 m
1 259096	18.0	6.0	0.8	50 m
1 259106	24.0	8.0	1.0	50 m
1 259116	39.0	13.0	1.2	50 m

# RAUCROSS® DS 3

## HIGH SHRINK RATE

Flame-retardant RAUCROSS heat-shrink sleeve, for components with large variations in diameter, to SAE-AMS-DTL-23053/5 class 1

### Technical values

Properties	Test method	RAU-VPE 142 (Crosslinked, modified polyolefin)
<b>Physical:</b>		
Tensile strength	ASTM D 638	13 N/mm <sup>2</sup>
Elongation at break	ASTM D 638	300 %
Change in length during shrinking	ASTM D 2671	+1 % to -10 %
Water absorption	DIN 53495-1	< 0.2 %
Spec. weight	DIN 53479	1.45 g/cm <sup>3</sup>
<b>Thermal:</b>		
Permanent heat resistance		-55 °C to +135 °C short-term: up to +200 °C
Shrink temperature		> 90 °C
Thermal shock (4 h at 200 °C)	ASTM D 2671	No dropping and flowing, no formation of cracks
Thermal ageing (168 h at 175 °C)	ASTM D 2671	
Elongation at break		> 200 %
Flexibility in cold conditions (-55 °C)	ASTM D 2671	No formation of cracks
Burning behaviour	UL 224	Passed
<b>Chemical:</b>		
Solvent resistance		Good
Copper tolerance	ASTM D 2671	Non-corrosive
<b>Electrical:</b>		
Dielectric strength	ASTM D 2671	20 kV/mm
Volume resistivity	ASTM D 257	10 <sup>14</sup> Ω cm

# RAUCROSS® DS 4

Flame-retardant RAUCROSS heat-shrink sleeve, for components with very large variations in diameter



up 4 : 1



> 115 °C to 250 °C



+135 °C  
-55 °C

**Material:**

Crosslinked, modified polyolefin

**Standard colours::**

Black 98001



Mat. No	Internal diameter (mm)		Wall thickness fully recovered	Length
	min. as supplied	Max. fully recovered		
1084002	19	5	1.7	1.22 m
1084003	25	7	1.7	1.22 m
1084004	38	10	1.7	1.22 m
1084005	50	14	1.7	1.22 m
1084006	76	21	1.7	1.22 m
1084007	102	27	1.7	1.22 m
1084008	115	37	1.7	1.22 m



# RAUCROSS® DS 4

Flame-retardant RAUCROSS heat-shrink sleeve, for components with very large variations in diameter

## Technical values

Properties	Test method	RAU-VPE 142 (Crosslinked, modified polyolefin)
<b>Physical:</b>		
Tensile strength	ASTM D 2671	13 N/mm <sup>2</sup>
Elongation at break	ASTM D 2671	500 %
Change in length during shrinkage	ASTM D 2671	±5 %
Water absorption	DIN 53495-1	< 0.2 %
Spec. weight	DIN 53479	1.34 g/cm <sup>3</sup>
<b>Thermal:</b>		
Permanent heat resistance		-55 °C to +135 °C
Shrink temperature		> 100 °C
Thermal shock (4 h at 250 °C)	ASTM D 2671	No dropping and flowing, no formation of cracks
Thermal ageing (168 h at 175 °C)	ASTM D 2671	
Elongation at break		> 350 %
Flexibility in cold conditions (-55 °C)	ASTM D 2671	No formation of cracks
Burning behaviour	UL 224	Passed
<b>Chemical:</b>		
Solvent resistance		Good
Copper tolerance	UL 224	Non-corrosive
<b>Electrical:</b>		
Dielectric strength	VDE 303-21	20 kV/mm
Volume resistivity	ASTM D 876	10 <sup>14</sup> Ω cm

# RAUCROSS® DON

## TRANSPARENT

### Transparent, flexible RAUCROSS heat-shrink sleeve

- Labelling, marking and connection points remain visible



up 2 : 1



> 115 °C to 200 °C



+105 °C

-55 °C

#### Material:

Crosslinked, modified polyolefin

#### Standard colours::

Transparent 90003



### Measurement chart: RAUCROSS DON

Mat. No	Dim. D inches	Internal diameter (mm)		Wall thickness fully recovered s	Rolls
		min. as supplied D	Max. fully recovered d		
1082861	3/64	1.2	0.6	0.4	150 m
1082871	1/16	1.6	0.8	0.5	150 m
1082711	3/32	2.4	1.2	0.5	150 m
1082731	1/8	3.2	1.6	0.5	150 m
1082751	3/16	4.8	2.4	0.5	75 m
1082771	1/4	6.4	3.2	0.6	75 m
1082791	3/8	9.5	4.8	0.6	75 m
1082811	1/2	12.7	6.4	0.6	50 m
1082831	3/4	19.0	9.5	0.8	30 m
1082851	1	25.4	12.7	0.9	30 m
1082891	1 1/2	38.0	19.0	1.0	30 m
1082901	2	51.0	25.4	1.1	30 m

# RAUCROSS® DON

## TRANSPARENT

### Transparent, flexible RAUCROSS heat-shrink sleeve

- Labelling, marking and connection points remain visible

#### Technical values

Properties	Test method	RAU-VPE 145 (Crosslinked,modified polyolefin)
<b>Physical:</b>		
Tensile strength	DIN-EN-ISO 527/1-3	13 N/mm <sup>2</sup>
Elongation at break	DIN-EN-ISO 527/1-3	400 %
Change in length during shrinking	ASTM D 2671	±10 %
Water absorption	DIN 53495-1	< 0.2 %
Spec. weight	DIN 53479	1.05 g/cm <sup>3</sup>
<b>Thermal:</b>		
Permanent heat resistance		-55 °C to +105 °C short-term: up to +200 °C
Shrink temperature		> 115 °C
Thermal shock (4 h at 200 °C)	ASTM D 2671	No dropping and flowing, no formation of cracks
Thermal ageing (168 h at 158 °C)	ASTM D 2671	
Elongation at break		> 300 %
Flexibility in cold conditions (4h at -55 °C)	ASTM D 2671	No formation of cracks
Burning behaviour	ASTM D 876	Not flame-retardant
<b>Chemical:</b>		
Solvent resistance		Good
Copper tolerance	ASTM D 2671	Non-corrosive
<b>Electrical:</b>		
Dielectric strength	VDE 303-21	15-25 kV/mm
Volume resistivity	DIN-IEC 93	10 <sup>14</sup> Ω cm

# RAUCROSS® DO

## HALOGEN-FREE

### Low-cost, halogen-free RAUCROSS heat-shrink sleeve

- Suitable e.g. as a cover and corrosion protection for brackets and handles



up 2 : 1



> 90 °C to 200 °C



+125 °C  
-55 °C

#### Material:

Crosslinked, modified polyolefin

#### Standard colours::

Black 98001



### Measurement chart: RAUCROSS DO

Mat. No	Dim. D inches	Internal diameter (mm)		Wall thickness fully recovered s	Rolls
		min. as supplied D	Max. fully recovered d		
1082721	1/8	3.2	1.6	0.4	300 m
1082741	3/16	4.8	2.4	0.4	300 m
1082761	1/4	6.4	3.2	0.5	300 m
1082781	3/8	9.5	4.8	0.5	150 m
1082801	1/2	12.7	6.4	0.5	100 m
1082821	3/4	19.0	9.5	0.8	50 m
1082841	1	25.4	12.7	0.9	50 m
1267555	1 1/2	38.0	19.0	1.0	50 m
1267105	2	51.0	25.4	1.1	50 m

# RAUCROSS® DO

## HALOGEN-FREE

### Low-cost, halogen-free RAUCROSS heat-shrink sleeve

- Suitable e.g. as a cover and corrosion protection for brackets and handles

#### Technical values

Properties	Test method	RAU-VPE 145 (Crosslinked, modified polyolefin)
<b>Physical:</b>		
Tensile strength	DIN-EN-ISO 527/1-3	10 N/mm <sup>2</sup>
Elongation at break	DIN-EN-ISO 527/1-3	200 %
Longitudinal shrinkage	ASTM D 2671	≤ +5 % to -10 %
Water absorption	DIN 53495-1	< 0.15 %
Spec. weight	DIN 53479	1.4 g/cm <sup>3</sup>
<b>Thermal:</b>		
Permanent heat resistance		-55 °C to +125 °C
Shrink temperature		> 90 °C
Thermal ageing (168 h at 150 °C)	ASTM D 638	
Elongation at break		> 200 %
Flexibility in cold conditions (-55 °C)	ASTM D 2671	No formation of cracks
Burning behaviour	ASTM D 876	Not flame-retardant
<b>Chemical:</b>		
Solvent resistance		Good
Copper tolerance	ASTM D 2671	Non-corrosive
<b>Electrical:</b>		
Dielectric strength	ASTM D 2671	≥ 20 kV/mm
Volume resistivity	ASTM D 257	10 <sup>14</sup> Ω cm

# RAUCROSS® DSTT

## LOW SHRINK TEMPERATURE

### RAUCROSS heat-shrink sleeve

- For insulating temperature-sensitive components
- Shrinks from above 80 °C



up 2 : 1



> 80 °C to 200 °C



+105 °C  
-45 °C

#### Material:

Crosslinked, modified polyolefins

#### Standard colours::

Black 98001

Other colours on request.



### Measurement chart: RAUCROSS DSTT

Mat. No	Dim. D inches	Internal diameter (mm)		Wall thickness fully recovered s	Rolls
		min. as supplied D	Max. fully recovered d		
1080942	1/8	3.2	1.6	0.5	300 m
1080952	3/16	4.8	2.4	0.5	300 m
1080962	1/4	6.4	3.2	0.6	300 m
1080972	3/8	9.5	4.8	0.6	150 m
1080982	1/2	12.7	6.4	0.6	100 m
1080992	3/4	19.0	9.5	0.8	50 m
1081002	1	25.4	12.7	0.9	50 m

# RAUCROSS® DSTT

## LOW SHRINK TEMPERATURE

### RAUCROSS heat-shrink sleeve

- For insulating temperature-sensitive components
- Shrinks from above 80 °C

### Technical values

Properties	Test method	RAU-VPE 1411 (Crosslinked, modified polyolefin)
<b>Physical:</b>		
Tensile strength	DIN-EN-ISO 527/1-3	12 N/mm <sup>2</sup>
Elongation at break	DIN-EN-ISO 527/1-3	> 350 %
Change in length during shrinking	ASTM D 2671	max. 6 %
Water absorption	DIN 53495-1	≤ 0.2 %
Spec. weight	DIN 53479	1.1 g/cm <sup>3</sup>
<b>Thermal:</b>		
Permanent heat resistance		-45 °C to +105 °C
Shrink temperature		> 80 °C
Thermal shock (4 h, 200 °C)		No dropping and flowing, no formation of cracks
Thermal ageing (168 h at 158 °C)	ASTM D 2671	
Elongation at break		> 300 %
Flexibility in cold conditions (4h, -45 °C)	ASTM D 2671	No formation of cracks
Burning behaviour		Not flame-retardant
<b>Electrical:</b>		
Dielectric strength	VDE 303-21	> 20 kV/mm

# RAUCROSS® DSHF

HALOGEN-FREE, FLAME-RETARDANT

## High quality, flexible, RAUCROSS heat-shrink sleeve with outstanding properties

- Halogen-free
- Low smoke emission
- Self-extinguishing



up 2 : 1



> 110 °C to 200 °C



+105 °C  
-40 °C

### Material:

Crosslinked, modified polyolefin

### Standard colours::

Black 98001



## Measurement chart: RAUCROSS DSHF

Mat. No	Dim. D inches	Internal diameter (mm)		Wall thickness fully recovered s	Rolls
		min. as supplied D	Max. fully recovered d		
1 241602	1/16	1.6	0.8	0.4	300 m
1 241612	3/32	2.4	1.2	0.5	300 m
1 241622	1/8	3.2	1.6	0.5	300 m
1 241632	3/16	4.8	2.4	0.5	300 m
1 241642	1/4	6.4	3.2	0.6	300 m
1 241652	3/8	9.5	4.8	0.6	150 m
1 241662	1/2	12.7	6.4	0.6	100 m
1 241672	3/4	19.0	9.5	0.7	50 m
1 241682	1	25.4	12.7	0.9	50 m
1 241692	1 1/2	38.0	19.0	1.0	50 m
1 241702	2	51.0	25.4	1.1	50 m



# RAUCROSS® DSHF

## HALOGEN-FREE, FLAME-RETARDANT

### High quality, flexible, RAUCROSS heat-shrink sleeve with outstanding properties

- Halogen-free
- Low smoke emission
- Self-extinguishing

#### Technical values

Properties	Test method	RAU-VPE 1419 (Crosslinked, modified polyolefin)
<b>Physical:</b>		
Tensile strength	DIN-EN-ISO 527/1-3	10 N/mm <sup>2</sup>
Elongation at break	DIN-EN-ISO 527/1-3	> 200 %
Change in length during shrinking		+5 % to -10 %
Water absorption	DIN 53495	< 0.2 %
Spec. weight	DIN 53479	1.38 g/cm <sup>3</sup>
<b>Thermal:</b>		
Permanent heat resistance		-40 °C to +105 °C
Shrink temperature		> 110 °C
Thermal shock (4 h at 175 °C)	ASTM D 2671	No dropping and flowing, no formation of cracks
Thermal ageing (168 h at 150 °C)	ASTM D 2671	
Elongation at break		> 100 %
Flexibility in cold conditions (at -40 °C)	ASTM D 2671	No formation of cracks
Burning behaviour	MVSS 302	Passed
<b>Chemical:</b>		
Solvent resistance	AMS-DTL-I-23053/5	Good
Copper tolerance	ASTM D 2671	Non-corrosive
Oxygen Index	ASTM D 2863	36 %
<b>Electrical:</b>		
Dielectric strength	ASTM D 2671	> 20 kV/mm
Volume resistivity	ASTM D 257	10 <sup>14</sup> Ω cm

# RAUCROSS® DSC

## CREASE-FREE

### Abrasion-resistant RAUCROSS heat-shrink sleeve with high shrink rate

- This RAUCROSS heat-shrink sleeve was designed especially for the insulation and protection of sharply bent objects
- High expansion rate for easy fitting
- Adheres tightly without creasing, even to tight radii
- Abrasion-resistant
- Resistant to petrol and oil
- Weathering and ageing-resistant
- Resistant to swelling pressure
- Halogen-free



up 3 : 1



> 110 °C to 250 °C



+135 °C  
-40 °C

#### Material:

Crosslinked, modified polyolefin

#### Standard colours::

Black 98001



### Measurement chart: RAUCROSS DSC

Mat. No	Type	Dimensions inches	typical object diameter mm	Rolls	Packaging unit
1 081212	DSC 18	3/4	9-15	120 m	9360 m
1 081252	DSC 27	1	12-23	200 m	6000 m
1 081492	DSC 39	1 1/2	18-29	150 m	4500 m
1 081512	DSC 51	2	25-35	120 m	3600 m
1 081032	DSC 60	2 1/2	25-40	120 m	3600 m
1 081472	DSC 76	3	35-60	75 m	1800 m
1 081952	DSC 100	4	55-75	75 m	1800 m

# RAUCROSS® DSC

## CREASE-FREE

### Abrasion-resistant RAUCROSS heat-shrink sleeve with high shrink rate

- This RAUCROSS heat-shrink sleeve was designed especially for the insulation and protection of sharply bent objects
- High expansion rate for easy fitting
- Adheres tightly without creasing, even to tight radii
- Abrasion-resistant
- Resistant to petrol and oil
- Weathering and ageing-resistant
- Resistant to swelling pressure
- Halogen-free

### Technical values

Properties	Test method	RAU-VPE 1410 (Crosslinked, modified polyolefin)
<b>Physical:</b>		
Tensile strength	DIN-EN-ISO 527/1-3	> 12 N/mm <sup>2</sup>
Elongation at break	DIN-EN-ISO 527/1-3	> 400 %
Shrink behaviour	REHAU method	Crease-free
Water absorption	DIN 53495	< 0.2 %
Spec. weight	ISO 1183	1.1 g/cm <sup>3</sup>
<b>Thermal:</b>		
Permanent heat resistance		-40 °C to +135 °C
Shrink temperature		> 110 °C
Thermal shock (4 h at 200 °C)	ASTM D 2671	No drops, flowing
Thermal ageing (168 h at 150 °C)	ASTM D 2671	
Elongation at break		> 300 %
Flexibility in cold conditions (4h at -55 °C)	ASTM D 2671	No formation of cracks
Burning behaviour		Not flame-retardant
<b>Chemical:</b>		
Chemical resistance		Good
Halogen proportion		Halogen-free
<b>Electrical:</b>		
Dielectric strength	DIN-EN 60243-1	> 15 kV/mm
Volume resistivity	DIN-IEC 60093	10 <sup>13</sup> Ω cm

# RAUCROSS® DOA

## WEATHERING AND AGEING-RESISTANT

### RAUCROSS heat-shrink sleeve for rod antennas

- Resistant to petrol and oil
- Weathering and ageing-resistant
- High shrink rates
- Gloss or matt surface
- UV stable



up 3 : 1



> 115 °C to 200 °C



+105 °C  
-40 °C

#### Material:

Crosslinked, modified polyolefin

#### Standard colours::

Black 98001  
gloss or matt



### Measurement chart: RAUCROSS DOA (K)

Mat. No	Internal diameter (mm)		Wall thickness fully recovered s	Rolls
	min. as supplied D	Max. fully recovered d		
1080692	4.8	2.4	0.5	300 m
1080762	6.4	2.4	0.5	250 m
1081102	6.4	2.5	0.65	250 m
1081193	6.0	2.0	0.5	400 m
1080077	6.0	2.5	0.5	400 m

# RAUCROSS® DOA

## WEATHERING AND AGEING-RESISTANT

### RAUCROSS heat-shrink sleeve for rod antennas

- Resistant to petrol and oil
- Weathering and ageing-resistant
- High shrink rates
- Gloss or matt surface
- UV stable

### Technical values

Properties	Test method	RAU-VPE (Crosslinked, modified polyolefin)
<b>Physical:</b>		
Tensile strength	DIN-EN-ISO 527/1-3	10 N/mm <sup>2</sup>
Elongation at break	DIN-EN-ISO 527/1-3	> 300 %
Longitudinal shrinkage	ASTM D 2671	2-8 %
Density	DIN 53479	approx. 1.1 g/cm <sup>3</sup>
Water absorption	DIN 53495	< 0.5 %
<b>Thermal:</b>		
Permanent heat resistance		-40 °C to +105 °C
Shrink temperature		> 115 °C
Thermal ageing (168 h at 136 °C)	ASTM D 2671	
Tensile strength		> 10 N/mm <sup>2</sup>
Elongation at break		> 250 %
Flexibility in cold conditions	ASTM D 2671	No formation of cracks
Thermal shock (4h, 200 °C)	ASTM D 2671	No dropping, flowing, no formation of cracks
Burning behaviour	MVSS 302	Not self-extinguishing
<b>Chemical:</b>		
Solvent resistance		Good
Corrosion effect		Non-corrosive
Copper tolerance		Non-corrosive
<b>Electrical:</b>		
Dielectric strength	VDE 303-21	15-25 kV/mm
Volume resistivity	DIN-IEC 93	10 <sup>14</sup> Ω cm

# RAUCROSS® DOU

## COLOURED-TRANSPARENT

### RAUCROSS heat-shrink sleeve as a cover for fluorescent pipes

- Decorative light effects
- Splinter protection
- Absorption of selected wavelength ranges



2 : 1



> 115 °C to 200 °C



+90 °C  
-40 °C

#### Material:

Crosslinked, modified polyolefin

#### Colours:

Colourless-transparent	90003
Red-transparent	95051
Yellow-transparent	93059
Green-transparent	99079
Blue-transparent	96810

(Note! Minimum order quantity)



### Measurement chart: RAUCROSS DOU

Mat. No	Type	for fluorescent pipes	with diameter	Rolls
1083341	DOU 26 FS	T8	26 mm	100 m
1081342	DOU 26 MS	T8	26 mm	80 m

# RAUCROSS® DOU

## COLOURED-TRANSPARENT

### RAUCROSS heat-shrink sleeve as a cover for fluorescent pipes

- Decorative light effects
- Splinter protection
- Absorption of selected wavelength ranges

#### Technical values

Properties	Test method	RAU-VPE (Crosslinked, modified polyolefin)
<b>Physical:</b>		
Tensile strength	DIN-EN-ISO 527/1-3	12 N/mm <sup>2</sup>
Elongation at break	DIN-EN-ISO 527/1-3	> 300 %
Change in length during shrinking	ASTM D 2671	≤ 10 %
Spec. weight	DIN 53479	0.93 g/cm <sup>3</sup>
<b>Thermal:</b>		
Permanent heat resistance		-40 °C to +90 °C
Shrink temperature		> 115 °C
Thermal shock (4 h at 200 °C)	ASTM D 2671	No dropping, flowing, no formation of cracks
Thermal ageing (168 h at 150 °C)	ASTM D 2671	
Elongation at break		> 150 %
Flexibility in cold conditions (4h at -55 °C)	ASTM D 2671	No formation of cracks
<b>Electrical:</b>		
Dielectric strength	VDE 303-21	> 15 kV/mm
Volume resistivity	DIN-IEC 93	10 <sup>14</sup> Ω cm

RAUCROSS DOU is suitable for conventional, white halogen lamps for general lighting in open lights without particularly pronounced (intensive) wavelengths in the UV ray range, and for use in dry environments indoors without mechanical loading or the influence of chemical fluids. Shatter protection not applied in the minus temperature range.

# RAUCROSS® DSNK 3/DSNK 4

WITH ADHESIVE, HIGH SHRINK RATES

## Semi-rigid RAUCROSS heat-shrink sleeve with interior hot-melt adhesive coating

- Watertight encapsulation and strain relief
- Shrink rates 3:1 and 4:1



up 4 : 1



> 110 °C to 200 °C



+110 °C  
-55 °C

### Material:

Crosslinked, modified polyolefin

### Standard colours::

Black 98001/90300

### Special colours:

White, Red, Blue, Yellow, Transparent

(Note: Minimum order quantities)



### Measurement chart: RAUCROSS DSNK 3: Shrink rate 3:1

Mat. No	Internal diameter (mm)		Wall thickness fully recovered s, of which adhesive		Rolls
	min. as supplied D	Max. fully recovered d			
1 253375	3.0	1.0	1.0	0.5	300 m*
1 246580	4.8	1.6	1.0	0.5	300 m
1 253385	6.0	2.0	1.0	0.5	300 m*
1 253395	9.0	3.0	1.3	0.6	150 m*
1 253405	12.0	4.0	1.5	0.7	100 m*
1 253415	18.0	6.0	2.0	0.8	50 m*
1 253425	24.0	8.0	2.5	1.0	50 m*
1 253435	39.0	13.0	2.5	1.0	30 m

\* Also available in small rolls in a dispenser box (see Page 42)

### Measurement chart: RAUCROSS DSNK 4: Shrink rate 4:1

Mat. No	Internal diameter (mm)		Wall thickness fully recovered s, of which adhesive		Rolls
	min. as supplied D	Max. fully recovered d			
1 253305	4	1	1.0	0.5	300 m
1 253315	8	2	1.0	0.5	150 m
1 253325	12	3	1.3	0.6	100 m
1 253335	16	4	1.8	0.8	50 m
1 253345	24	6	2.1	0.8	50 m
1 253355	32	8	2.5	1.0	50 m
1 253365	52	13	2.5	1.0	30 m

Note: The extended material number applies for all SAP countries: 1 = 1



# RAUCROSS® DSNK 3/DSNK 4

## WITH ADHESIVE, HIGH SHRINK RATES

### Semi-rigid RAUCROSS heat-shrink sleeve with interior hot-melt adhesive coating

- Watertight encapsulation and strain relief
- Shrink rates 3:1 and 4:1

#### Technical values

Properties	Test method	RAU-VPE 1420 (Crosslinked, modified polyolefin)
------------	-------------	---

#### Physical:

Tensile strength	ASTM D 638	11 N/mm <sup>2</sup>
Elongation at break	ASTM D 638	300 %
Change in length during shrinking	ASTM D 2671	+1 % to -15 %
Water absorption*	DIN 53495-1	< 0.5 %
Spec. weight	DIN 53479	1.45 g/cm <sup>3</sup>

#### Thermal:

Permanent heat resistance		-55 °C to +110 °C
Shrink temperature		> 110 °C
Thermal shock (4 h at 250 °C)	ASTM D 2671	No drooping and flowing, no formation of cracks
Thermal ageing (168 h at 175 °C)	ASTM D 638	
Elongation at break		> 200 %
Flexibility in cold conditions (-55 °C)	ASTM D 2671	No formation of cracks
Burning behaviour	ASTM D 2671	Flame-retardant (colours only)*

#### Chemical:

Copper tolerance	ASTM D 2671	Non-corrosive
------------------	-------------	---------------

#### Electrical:

Dielectric strength*	ASTM D 2671	> 15 kV/mm
Volume resistivity	DIN-IEC 93	10 <sup>14</sup> Ω cm

#### Adhesive:

Melting point	ASTM E 28	123 °C
Peel strength of the adhesive on:		
PVC		85 N/25 mm
Steel		44 N/25 mm
Copper		35 N/25 mm

\* Properties for external material RAU-VPE 1420

# RAUCROSS® DSNK-BOX

## RAUCROSS heat-shrink sleeve box, practical small rolls in a dispenser box

- With adhesive coating
- Rapid shrinking
- Easy to dispense
- Leftover quantities remain protected



3 : 1



> 110 °C to 200 °C



+110 °C  
-55 °C

### Material:

Crosslinked, modified polyolefin

### Standard colours::

Black 98001/90300



## Measurement chart: Heat-shrink sleeves 3:1 with hot-melt adhesive coating

Mat. No	Dim. D inches	Internal diameter (mm)		Wall thickness fully recovered s	Contents per box
		min. as supplied D	Max. fully recovered d		
1 261715	3		1	1.0	5 m
1 261725	6		2	1.0	3.5 m
1 261735	9		3	1.4	3 m
1 261745	12		4	1.8	2.5 m
1 261755	18		6	2.2	2 m
1 261765	24		8	2.5	1.5 m

# RAUCROSS® DSNK-BOX

## RAUCROSS heat-shrink sleeve box, practical small rolls in a dispenser box

- With adhesive coating
- Rapid shrinking
- Easy to dispense
- Leftover quantities remain protected

### Technical values

Properties	Test method	RAU-VPE 1420 (Crosslinked, modified polyolefin)
<b>Physical:</b>		
Tensile strength	ASTM D 638	11 N/mm <sup>2</sup>
Elongation at break	ASTM D 638	300 %
Change in length during shrinking	ASTM D 2671	+ 1 % to -15 %
Water absorption	DIN 53495-1	< 0.5 %
Spec. weight	DIN 53479	1.45 g/cm <sup>3</sup>
<b>Thermal:</b>		
Permanent heat resistance		-55 °C to +110 °C
Shrink temperature		> 110 °C
Thermal shock (4 h at 200 °C)	ASTM D 2671	No dropping and flowing, no formation of cracks
Thermal ageing (168 h at 175 °C)	ASTM D 638	
Elongation at break		> 200 %
Flexibility in cold conditions (-55 °C)	ASTM D 2671	No formation of cracks
Burning behaviour	ASTM D 2671	Flame-retardant (colours only)*
<b>Chemical:</b>		
Copper tolerance	ASTM D 2671	Non-corrosive
<b>Electrical:</b>		
Dielectric strength*	ASTM D 2671	> 15 kV/mm
Volume resistivity	DIN-IEC 93	10 <sup>14</sup> Ω cm
<b>Adhesive:</b>		
Melting point	ASTM E 28	123 °C
Peel strength of the adhesive on:		
PVC		85 N/25 mm
Steel		44 N/25 mm
Copper		35 N/25 mm

\* Properties for external material RAU-VPE 1420

# RAUCROSS® MO/MOK

## MEDIUM-WALLED

Medium-walled RAUCROSS heat-shrink sleeve, available with or without interior adhesive coating

- Moisture-proof insulation
- High shrink rates
- Nominal voltage 0.6/1 kV
- UV resistant



up 4 : 1



> 120 °C to 200 °C



+110 °C  
+80 °C (with adhesive)  
-55 °C

### Material:

Crosslinked, modified polyolefin

### Standard colour:

Black 98001



MO	Mat. No	MOK	Internal diameter (mm)		Wall thickness fully recovered s (without adhesive)	Bag contents Delivery format 1m lengths	
	without adhesive		with adhesive	min. as supplied D			Max. fully recovered d
1	297942	1	297972	8	2	1.70	10
1	297944	1	297974	12	4	2.00	10
1	297945	1	297975	20	6	2.50	5
1	297947	1	297977	32	8	2.50	4
1	297950	1	297981	40	12	2.50	3
1	297952	1	297982	55	20	2.70	3
1	297954	1	297984	70	25	3.00	3
1	297955	1	297985	90	30	3.00	3
1	297964	1	297987	115	40	3.00	3
1	297965	1	297990	170	60	3.00	3
1	297967	1	297991	230	70	3.00	2
1	297970	1	297992	300	80	3.00	1
1	297971	1	297994	350	110	3.00	1

# RAUCROSS® MO/MOK

## MEDIUM-WALLED

### Medium-walled RAUCROSS heat-shrink sleeve, available with or without interior adhesive coating

- Moisture-proof insulation
- High shrink rates
- Nominal voltage 0.6/1 kV
- UV resistant

### Technical values

Properties	Test method	RAU-VPE 240 (RAU-COL 23) (Crosslinked, modified polyolefin)
<b>Physical:</b>		
Tensile strength	DIN-EN-ISO 527/1-3	13 N/mm <sup>2</sup>
Elongation at break	DIN-EN-ISO 527/1-3	> 350 %
Change in length during shrinking	ASTM D 2671	≤ 10 %
Water absorption	DIN 53495-1	< 0.2 %
Spec. weight	DIN 53479	1.05 g/cm <sup>3</sup>
Shore hardness	DIN 53505	47 Shore D
<b>Thermal:</b>		
Permanent heat resistance	DIN IEC 216	-55 °C to +110 °C - without adhesive / -55 °C to +80 °C - with adhesive
Shrink temperature		> 120 °C
Thermal ageing (168 h at 150 °C)	ASTM D 2671	
Elongation at break	DIN-EN-ISO 527/1-3	≥ 250 %
<b>Chemical:</b>		
Fungi and rotting	ISO 846	None
Copper tolerance	ASTM D 2671	Non-corrosive
<b>Electrical:</b>		
Dielectric strength	IEC 243	> 20 kV/mm
Volume resistivity	DIN-IEC 93	10 <sup>14</sup> Ω cm
<b>Adhesive:</b>		
Peel strength PE	DIN 30672	> 4 N/cm
Softening point/Adhesive:	ASTM D E8	80 °C

# RAUCROSS® WS/WSK

## THICK-WALLED

### Particularly thick-walled RAUCROSS heat-shrink sleeve, available with or without interior adhesive coating

- Moisture-proof insulation and corrosion protection for cable laid in the ground
- High shrink rates
- Extremely resistant to mechanical damage
- Nominal voltage 0.6/1 kV
- UV resistant



up 4 : 1



> 120 °C to 200 °C



+110 °C  
+80 °C (with adhesive)  
-55 °C

#### Material:

Crosslinked, modified polyolefin

#### Standard colour:

Black 98001



### Measurement chart: RAUCROSS WS/WSK

WS	Mat. No		Internal diameter (mm)		Wall thickness fully recovered s (without adhesive)	Delivery format 1m lengths
	with adhesive	WSK with adhesive	min. as supplied D	Max. fully recovered d		
1297997	1298071	9	3	1.80	10	
1298021	1298077	12	4	2.40	10	
1298027	1298081	20	6	2.70	5	
1298031	1298087	30	8	3.20	4	
1298037	1298091	40	12	4.10	3	
1298041	1298097	55	16	4.10	3	
1298047	1298101	75	25	4.10	3	
1298051	1298102	90	30	4.30	3	
1298057	1298107	130	40	4.30	3	
1298061	1298111	160	55	4.30	3	
1298067	1298112	175	60	4.30	3	

# RAUCROSS® WS/WSK

## THICK-WALLED

### Particularly thick-walled RAUCROSS heat-shrink sleeve, available with or without interior adhesive coating

- Moisture-proof insulation and corrosion protection for cable laid in the ground
- High shrink rates
- Extremely resistant to mechanical damage
- Nominal voltage 0.6/1 kV
- UV resistant

### Technical values

Properties	Test method	RAU-VPE 1420 (RAU-COL 23) (Crosslinked, modified polyolefin)
<b>Physical:</b>		
Tensile strength	DIN-EN-ISO 527/1-3	13 N/mm <sup>2</sup>
Elongation at break	DIN-EN-ISO 527/1-3	350 %
Change in length during shrinking	ASTM D 2671	≤ 10 %
Water absorption	DIN 53495-1	< 0.2 %
Spec. weight	DIN 53479	1.05 g/cm <sup>3</sup>
Shore hardness	DIN 53505	47 Shore D
<b>Thermal:</b>		
Permanent heat resistance	DIN IEC 216	-55 °C to +110 °C - without adhesive / -55 °C to +80 °C - with adhesive
Shrink temperature		> 120 °C
Thermal ageing (168 h at 150 °C)	ASTM D 2671	
Elongation at break		≥ 300 %
<b>Chemical:</b>		
Rotting	ISO 846	Rate 1
Copper tolerance	ASTM D 2671	Non-corrosive
<b>Electrical:</b>		
Dielectric strength	IEC 243	> 20 kV/mm
Volume resistivity	DIN-IEC 93	10 <sup>14</sup> Ω cm
<b>Adhesive:</b>		
Peel strength PE	DIN 30672	> 4 N/cm
Softening point/Adhesive:	ASTM D E8	80 °C

# RAUCROSS® WSK 6

## Thick-walled RAUCROSS heat-shrink sleeve with very high shrink rate with internal hot-melt adhesive coating

- Moisture-proof insulation
- Very high shrink rate
- Extremely resistant to mechanical damage
- Nominal voltage 0.6/1 kV



up 6 : 1



> 115 °C to 200 °C



+135 °C  
-55 °C

### Material:

Crosslinked, modified polyolefin

### Standard colours::

Black 98001



Mat. No	Internal diameter (mm)		Wall thickness fully recovered	Length
	min. as supplied	Max. fully recovered		
1086001	19	3.5	3.2	1.22 m
1086002	32	6	3.4	1.22 m
1086003	44	7.5	3.6	1.22 m
1086004	50	8.5	4.3	1.22 m
1086005	69	12	4.8	1.22 m
1086006	88	18	4.8	1.22 m
1086007	119	23	4.8	1.22 m
1086008	235	40	4.8	1.22 m



# RAUCROSS® WSK 6

## Thick-walled RAUCROSS heat-shrink sleeve with very high shrink rate with internal hot-melt adhesive coating

- Moisture-proof insulation
- Very high shrink rate
- Extremely resistant to mechanical damage
- Nominal voltage 0.6/1 kV

### Technical values

Properties	Test method	RAU-VPE 1420 (RAU-COL 23) (Crosslinked, modified polyolefin)
------------	-------------	--

#### Physical:

Tensile strength	ASTM D 2671	13 N/mm <sup>2</sup>
Elongation at break	ASTM D 2671	350 %
Change in length during shrinking	ASTM D 2671	≤ 10 %
Water absorption	DIN 53495-1	< 0.2 %
Spec. weight	DIN 53479	1.05 g/cm <sup>3</sup>
Shore hardness	DIN 53505	47 Shore

#### Thermal:

Permanent heat resistance		-55 °C to +110 °C
Shrink temperature		> 125 °C
Thermal ageing (168 h at 150 °C)	ASTM D 2671	
Tensile strength		
Elongation at break		> 300 %
Flexibility in cold conditions (4h at -55 °C)	ASTM D 2671	No formation of cracks

#### Chemical:

Rotting	ISO 846	Passed
Copper tolerance	ASTM D 2671	Non-corrosive

#### Electrical:

Dielectric strength	VDE 303-21	> 20 kV/mm
Volume resistivity	ASTM D 876	10 <sup>14</sup> Ω cm

#### Adhesive:

Softening range		+ 85 °C
-----------------	--	---------

\* Outer sheath

# RAUCROSS® PVDF

TEMPERATURE-RESISTANT UP TO +175 °C

## Semi-rigid RAUCROSS heat-shrink sleeve made from modified polyvinylidene fluoride

Outstanding properties:

- High temperature resistance
- Self-extinguishing
- Extremely thin-walled
- Good resistance to chemicals and solvents
- Transparent
- MIL-I-23053/8



2 : 1



> 175 °C to 250 °C



+175 °C  
-55 °C

### Material:

Crosslinked, modified fluoropolymer

### Standard colours::

Transparent 90003

### Special colours:

On request



## Measurement chart: RAUCROSS PVDF

Mat. No	Dim. D inches	Internal diameter (mm)		Wall thickness fully recovered s	Packaging unit Rolls
		min. as supplied D	Max. fully recovered d		
1 254786	3/64	1.2	0.6	0.25	300 m
1 254796	1/16	1.6	0.8	0.25	300 m
1 254806	3/32	2.4	1.2	0.25	300 m
1 254816	1/8	3.2	1.6	0.25	300 m
1 254826	3/16	4.8	2.4	0.25	300 m
1 254836	1/4	6.4	3.2	0.30	300 m
1 254846	3/8	9.5	4.8	0.30	150 m
1 254856	1/2	12.7	6.4	0.30	100 m
1 254866	3/4	19.0	9.5	0.40	50 m
1 254876	1	25.4	12.7	0.50	50 m

# RAUCROSS® PVDF

TEMPERATURE-RESISTANT UP TO +175 °C

## Semi-rigid RAUCROSS heat-shrink sleeve made from modified polyvinylidene fluoride

Outstanding properties:

- High temperature resistance
- Self-extinguishing
- Extremely thin-walled
- Good resistance to chemicals and solvents
- Transparent
- MIL-I-23053/8

### Technical values

Properties	Test method	RAU-PVDFX 10 („Kynar“) (Crosslinked, modified fluoropolymer)
<b>Physical:</b>		
Tensile strength	IEC 60684-2	40 N/mm <sup>2</sup>
Elongation at break	IEC 60684-2	380 %
Change in length during shrinking	ASTM D 2671	± 10 %
Water absorption	DIN 53495-1	< 0.5 %
Spec. weight	DIN 53479	1.8 g/cm <sup>3</sup>
<b>Thermal:</b>		
Permanent heat resistance		-55 °C to +175 °C
Shrink temperature		> 175 °C
Thermal shock (4 h at 250 °C)	ASTM D 2671	No dropping and flowing, no formation of cracks
Thermal ageing (168 h at 200 °C)	ASTM D 638	
Elongation at break		> 200 %
Flexibility in cold conditions (-55 °C)	ASTM D 2671	No formation of cracks
Burning behaviour	ASTM D 876	Self-extinguishing
<b>Chemical:</b>		
Solvent resistance		Very good
<b>Electrical:</b>		
Dielectric strength	VDE 303-21	> 30 kV/mm

# RAUCROSS® DSV

TEMPERATURE-RESISTANT UP TO +200 °C

## Highly abrasion-resistant fluoroelastomer heat-shrink sleeve for use at extreme application temperatures

- Extremely resistant to mechanical and chemical damage
- Excellent resistance to lubricants and fuels
- Flexible
- Self-extinguishing



2 : 1



> 175 °C to 250 °C



+220 °C

-55 °C

### Material:

Crosslinked fluoroelastomer

### Standard colours::

Black 98001



## Measurement chart: RAUCROSS DSV

Mat. No	Dim. D inches	Internal diameter (mm)		Wall thickness fully recovered s	Rolls
		min. as supplied D	Max. fully recovered d		
1267226	1/8	3.2	1.6	0.8	50 m
1267236	3/16	4.8	2.4	0.9	50 m
1267246	1/4	6.4	3.2	0.9	50 m
1267256	3/8	9.5	4.8	0.9	50 m
1267266	1/2	12.7	6.4	0.9	30 m
1267276	3/4	19.0	9.5	1.1	30 m
1267286	1	25.4	12.7	1.4	30 m

# RAUCROSS® DSV

TEMPERATURE-RESISTANT UP TO +200 °C

## Highly abrasion-resistant fluoroelastomer heat-shrink sleeve for use at extreme application temperatures

- Extremely resistant to mechanical and chemical damage
- Excellent resistance to lubricants and fuels
- Flexible
- Self-extinguishing

### Technical values

Properties	Test method	RAU-SR 300 („Viton“) (Crosslinked fluoroelastomer)
<b>Physical:</b>		
Tensile strength	IEC 60684-2	> 13 N/mm <sup>2</sup>
Elongation at break	IEC 60684-2	> 350 %
Change in length during shrinking		≤ 10 %
Water absorption	ASTM D 570	< 0.2 %
Spec. weight	ASTM D 792	1.9 g/cm <sup>3</sup>
<b>Thermal:</b>		
Permanent heat resistance		-55 °C to +220 °C
Shrink temperature		> 175 °C
Thermal shock (4 h at 300 °C)	ASTM D 2671	No dropping and flowing, no formation of cracks
Flexibility in cold conditions (-55 °C)	ASTM D 2671 C	No formation of cracks
Burning behaviour	ASTM D 876	Self-extinguishing
<b>Chemical:</b>		
Solvent resistance	MIL-I-23053/13	Very good
<b>Electrical:</b>		
Dielectric strength	ASTM D 2671	> 12 kV/mm

# RAUCROSS® DSDR

## ABRASION-RESISTANT AND OIL-RESISTANT

### Very flexible and extremely abrasion-resistant elastomer heat-shrink sleeve

- Excellent resistance to oils and fuels
- Self-extinguishing
- Application temperature: -75 to +150 °C



2 : 1



> 135 °C to 250 °C



+150 °C  
-75 °C

#### Material:

Crosslinked, modified elastomer

#### Standard colours::

Black 98001



### Measurement chart: RAUCROSS DSDR

Mat. No	Dim. D inches	Internal diameter (mm)		Wall thickness fully recovered s	Rolls
		min. as supplied D	Max. fully recovered d		
1267296	1/8	3.2	1.6	0.7	50 m
1267306	3/16	4.8	2.4	0.8	50 m
1267316	1/4	6.4	3.2	0.9	50 m
1267326	3/8	9.5	4.8	1.0	50 m
1267336	1/2	12.7	6.4	1.2	30 m
1267346	3/4	19.0	9.5	1.4	30 m
1267356	1	25.4	12.7	1.8	30 m
1267366	1 1/2	38.0	19.0	2.4	30 m

# RAUCROSS® DSDR

## ABRASION-RESISTANT AND OIL-RESISTANT

### Very flexible and extremely abrasion-resistant elastomer heat-shrink sleeve

- Excellent resistance to oils and fuels
- Self-extinguishing
- Application temperature: -75 to +150 °C

#### Technical values

Properties	Test method	RAU-SR 450 (Crosslinked, modified elastomer)
<b>Physical:</b>		
Tensile strength	ASTM D 638	> 14 N/mm <sup>2</sup>
Elongation at break	ASTM D 638	> 350 %
Change in length during shrinking		≤ 15 %
Water absorption	ASTM D 570	< 0.2 %
Spec. weight	ASTM D 792	1.5 g/cm <sup>3</sup>
<b>Thermal:</b>		
Permanent heat resistance		-75 °C to +150 °C
Shrink temperature		> 135 °C
Thermal shock (4 h at 200 °C)	ASTM D 2671	No dropping, flowing, no formation of cracks
Thermal ageing (168 h at 160 °C)	ASTM D 638	
Elongation at break		> 200 %
Flexibility in cold conditions (-75 °C)	ASTM D 2671 C	No formation of cracks
Burning behaviour	ASTM D 876	Self-extinguishing
<b>Chemical:</b>		
Solvent resistance		Good
<b>Electrical:</b>		
Dielectric strength	ASTM D 2671	> 20 kV/mm

# RAUCROSS® SKE/SKE-V

## HEAT-SHRINK END CAPS

RAUCROSS end caps seal the ends of cables, making them pressure and moisture-tight. They are suitable for plastic and metal sheathed cables up to 0.6/1 kV. The cap is coated on the inside with hot-melt adhesive. The caps are available with valves fitted for compressed air monitored cables.

End caps with internal hot-melt adhesive coating.

**Material:**

Crosslinked, modified polyolefin

**Standard colour:**

Black 98001



Measurement chart: RAUCROSS SKE dimensions in mm

Mat. No SKE without valve	Mat. No SKE-V with valve	Area of application Cable diameter from to	Internal diameter (without adhesive)		Length L <sub>min</sub>	Wall thickness S <sub>min</sub>	Packaging unit	
			D <sub>min</sub>	d <sub>max</sub>			Bag	Box
1081912	-	4- 10	12	4	35	2.0	500	1000
1645709	1293290	8- 20	22	8	60	2.5	100	700
1645719	1293280	16- 35	40	15	85	3.0	100	500
1645729	1291520	25- 50	55	22	125	3.2	50	250
1292010	1293270	45- 70	75	43	120	3.7	125	125
1645749	1282783	45- 95	100	42	120	3.9	50	50
1645759	1282993	75-120	125	70	130	4.0	45	45



# RAUCROSS® SKE/SKE-V

## HEAT-SHRINK END CAPS

RAUCROSS end caps seal the ends of cables, making them pressure and moisture-tight. They are suitable for plastic and metal sheathed cables up to 0.6/1 kV. The cap is coated on the inside with hot-melt adhesive. The caps are available with valves fitted for compressed air monitored cables.

End caps with internal hot-melt adhesive coating.

### Technical values

Properties	Test method	RAUCROSS SKE RAU-VPE 250 (Crosslinked, modified polyolefin)
<b>Physical:</b>		
Tensile strength	DIN-EN-ISO 527/1-3	14 N/mm <sup>2</sup>
Elongation at break	DIN-EN-ISO 527/1-3	400 %
Water absorption (24 h at 23 °C)	DIN 53495	≤ 0.5 %
Shore hardness	DIN 53505	48 Shore D
<b>Thermal:</b>		
Permanent heat resistance	VDE 0304 part 2	+60 °C
Shrink temperature		> 130 °C
Thermal ageing (168 h at 150 °C)		
Tensile strength	DIN 53455	14 N/mm <sup>2</sup>
Elongation at break	DIN 53455	300 %
Cold crack temperature	DIN 53453	No cracking at -40 °C
<b>Chemical:</b>		
Copper tolerance	DIN 53495	Non-corrosive
<b>Electrical:</b>		
Dielectric strength	VDE 303-21	12 kV/mm
Volume resistivity	DIN-IEC 93	> 10 <sup>12</sup> Ω cm
<b>Adhesive:</b>		
Peel strength (23 °C)	DIN 53282	
End cap/PE		100 N/25 mm
End cap/lead		50 N/25 mm
Softening point	DIN 52011	140 ±10 °C
<b>Function:</b>		
Internal pressure tightness (60 °C, 30 min)	DIN 47645	No leaktightness (at 0.8 bar and 1.5 bar excess pressure on PE)
Resistance to shrinkage	DIN 47645	No tearing open

# REHAU HEAT-SHRINK PRODUCTS

## HEAT-SHRINK SLEEVES MADE FROM RAU-PVC SOFT

---

Our product range includes nominal dimensions from 1.8 - 210 mm internal diameter, with wall thicknesses from 0.2 - 3.0 mm (depending on the diameter).

We understand nominal dimensions to be: The diameter of the object/wall thickness to be covered, shrunk to the diameter of the object.

On delivery the internal diameter of REHAU heat-shrink sleeves made from RAU-PVC soft is larger than the nominal diameter, the wall thickness thinner in the same way.

If no special customer requirements exist, the supply diameter including tolerance and diameter for free shrinkage (starting diameter) will be specified by REHAU.

The shrink range for free shrinking can be up to 50 %.

### **Note:**

With the lateral shrinkage, longitudinal shrinkage also occurs, which in turn depends on the lateral shrinkage range. Due to the production methods, variations in longitudinal shrinkage may occur, which - especially for short fixed lengths - are to be determined based on historic values. REHAU heat-shrink sleeves made from RAU-PVC soft are not a standard article. Each article can be designed individually in dimension and material composition. In order to be able to shrink parts with tight bending radii without creasing, special designs with high longitudinal shrinkage are recommended (specification on request).

### **The material compositions:**

**RAU-PVC 9200:** Low-cost, fully coloured, abrasion-resistant, insulating, particularly suitable as a standard type, because this material can be used for a variety of applications.

**RAU-PVC 9205:** Suitable for outdoor use due to the special weathering and UV-resistant formulation. Used e.g. in sports facilities (posts and outdoor equipment).

**RAU-PVC 9210:** Transparent-crystal clear, suitable e.g. as protective packaging, if the contents need to be identifiable, and for all objects on which the printing still needs to be legible after shrinking.

# REHAU HEAT-SHRINK PRODUCTS

## PROCESSING TIPS FOR HEAT-SHRINK SLEEVES MADE FROM RAU-PVC SOFT

### Pretreatment:

The parts to be covered must be smooth and clean on the surface. Metal parts especially should be heated in advance to approx. 50 °C. In the case of fixed lengths the longitudinal shrinkage and longitudinal shrinkage variation are to be monitored.

### Processing equipment:

You can use drying ovens with circulating air, hot air blowers or infrared radiators. Please note that: The heat-shrink sleeve must be heated evenly all over.

### Shrink temperature:

REHAU heat-shrink sleeves made from RAU-PVC soft should preferably be shrunk at 100 °C-110 °C. The shrink time is longer at lower temperatures, at higher temperatures a shorter shrink time must be selected accordingly. The minimum shrink temperature should not fall below 80 °C.

The application or long-term temperature range of the PVC heat-shrink sleeves is -10 °C to +60 °C (see material code of practice AV0010 for RAU-PVC soft).

### Overheating is to be avoided in each case!

### Storage:

Due to the large supply diameter (greater than the diameter of the object), the suitability for use of the REHAU heat-shrink sleeve is even guaranteed if a certain amount of shrinkage should occur due to the effects of heat during transport or storage. However, we recommend that REHAU heat-shrink sleeves made from RAU-PVC soft are stored at temperatures below 25 °C, out of direct sunlight and in dry conditions, and that they are used within three months. The duration of the storage is easy to control, as the manufacturing date is noted on the label hanging on every sleeve bundle.

The boxes and packages are marked as heat-sensitive goods

### Information for ordering:

In the case of cylindrical, straight parts, the nominal diameter and wall thickness of the heat-shrink sleeve will suffice, where the wall thickness refers to the nominal diameter.

### Example:

Object diameter:	20 mm
Required wall thickness:	1.0 mm
Nominal dimension:	20/1 mm

Original, supply diameter and tolerances will be specified by REHAU. If it concerns bent parts or parts with different diameters, please specify the bend radius or the largest and smallest part diameters.

In the case of ribbed or profiled sleeves, please provide a sketch or sample. The wall thickness description refers in this case to the wall thickness without ribs and to the whole thickness with ribs.

### Example:

Object diameter	20 mm
Wall thickness without ribs:	1,0 mm
Wall thickness with ribs:	1.5 mm
Nominal dimensions:	20/1/1.5 mm

(Rib design according to the sketches in our standard range).

# REHAU HEAT-SHRINK PRODUCTS

## CHEMICAL RESISTANCE OF RAU-PVC SOFT

Medium, concentration	T (°C)	Level
Acetone	20	u
	60	u
Acetylene 100 %	20	bb
Battery acid	20	b
	60	bb
Alums all types, aqueous	20	b
	60	b
Aluminium salt, aqueous	20	b
	60	b
Formic acid 98 %	20	u
	60	u
90 %	20	u
	60	u
50 %	20	bb
	60	u
10 %	20	b
	60	bb
Ammonia, gaseous	20	b
	60	b
Ammonia, aqueous, conc.	20	b
	60	bb
10 %	20	b
	60	bb
Ammonium acetate, aqueous	20	b
	60	b
Ammonium carbonate, aqueous	20	b
	60	-
Ammonium chloride, aqueous	20	b
	60	b
Ammonium nitrate, aqueous	20	b
	60	b
Ammonium phosphate, aqueous	20	b
	60	b
Ammonium sulphate, aqueous	20	b
	60	b
Amyl alcohol, pure	20	bb
	60	u
Aniline 100 %	20	u
	60	u
Asphalt	20	bb
	60	bb-u
Barium salts, aqueous	20	b
	60	b
Benzaldehyde 100 %	20	u
	60	u
Benzaldehyde, aqueous cold total (0.3 %)	20	u
	60	u
Petrol see fuels		
Benzoic acid 100 %	20	b
	60	-
Benzoic acid, aqueous cold total	20	b
	60	-
Benzene 100 %	20	u
	60	u
Succinic acid, aqueous cold total	20	b
	60	-
Bisulphite, aqueous	40	b
	60	bb
Bleaching solution (12.5% Chlorine)	20	bb
	60	-
Floor polish	20	bb
	60	u
Borax, aqueous cold total	20	b
	60	-
Boric acid 100 %	20	b
	60	-

Medium, concentration	T (°C)	Level
Boric acid, aqueous cold total	20	b
	60	b
Bromine, aqueous 100 %	20	u
Bromine vapours low	20	u
Bromine vapours high	20	u
Bromine water cold total	20	-
Hydrogen bromide	40	b
Butane, aqueous 100 %	20	u
Butter	20	-
Butyric acid, conc.	20	u
20 %	20	bb
Butyl acetate 100 %	20	u
n-Butyl alcohol 100 % (Butanol)	20	u
	60	u
Calcium chloride, aqueous cold total	20	b
	60	b
Calcium nitrate, aqueous cold total	20	b
	60	b
Chlorine, aqueous 10 %	20	u
Chlorine, gaseous, moist 10 %	20	u
	60	u
Chlorine, gaseous, dry 100 %	20	u
	60	u
Chlorobenzene 100 %	20	u
	60	u
Bleaching powder (aqueous suspension)	20	bb
Chloroform 100 %	20	u
	60	u
Chlorosulphonic acid 100 %	20	u
	60	u
Chlorinated water cold total	20	u
Hydrogen chloride, gaseous high	20	-
	60	-
low	20	b
	60	-
Chrome baths, techn.	20	bb
	60	-
Chrome salts, bi and trivalent	60	b
Chromium sulphuric acid	20	u
	60	u
Cyclohexane 100 %	20	u
	60	u
Cyclohexanol 100 %	20	u
	60	u
Cyclohexanon 100 %	20	u
Decahydronaphthalene 100 %	20	u
	60	u
Dextrin, aqueous, saturated	60	b
Diethylether 100 %	20	u
Diesel oil, see fuels		
Dimethylformamide 100 %	20	u
	60	u
1,4-Dioxane 100 %	20	u
	60	u
Dixan solution ready to use	20	b
	60	b-bb
Fertiliser salt, aqueous	60	b
Iron salts, aqueous cold total	20	b
	60	b
Vinegar standard	20	b
	60	bb
Vinegar essence 50 %	20	bb
	60	u
Acetic acid (glacial acetic acid) 100 %	20	u
	60	u
Acetic acid, aqueous 50 %	20	bb

# REHAU HEAT-SHRINK PRODUCTS

## CHEMICAL RESISTANCE OF RAU-PVC SOFT

Medium, concentration	T (°C)	Level
10 %	60	u
	20	b
	60	bb
Acetic anhydride 100 %	20	u
	60	u
Acetic acid butylester (Butylacetate) 100 %	20	u
	60	u
Ethylacetate (vinegar) 100 %	20	u
	60	u
Ethanol, aqueous 96 %	20	bb
	60	u
50 %	20	bb
	60	bb
10 %	20	b
	60	bb
Ethanol undenatured 100 %	20	u
	60	u
Ethylbenzene 100 %	20	u
	60	u
Ethylchloride 100 %	20	u
Ethylene chloride 100 %	20	u
	60	u
2-Ethylhexanol 100 %	20	u
	60	u
Fats, animal and vegetable	20	u
Fats, aqueous emulsions	20	bb
Pine needle oil 100 %	20	u
Fixing salt 100 %	20	b
	60	b
Formaldehyde, aqueous 40 %	20	bb
Formalin	20	bb
Anti-freeze agent (vehicles)	20	b
	60	bb
Washing-up liquid, fluid	20	b
Glycerine 100 %	20	b-bb
	60	-
Glycerine, aqueous high	20	b
	60	bb
low	20	b
	60	b
Glycol (Ethylene glycol) 100 %	20	b-bb
	60	-
Glycol, aqueous high	20	b
	60	bb
low	20	b
	60	b
Hair shampoo	20	b
Urea cold total	20	b
	60	bb
Heating oil	20	bb-u
	60	u
Heptane 100 %	20	u
	60	u
Hexane 100 %	20	u
	60	u
Isooctane 100 %	20	u
	60	u
Isopsopanol 100 %	20	u
	60	u
Potash 50 %	20	bb
	60	u
25 %	20	b-bb
	60	bb
10 %	20	b
	60	b-bb
Potassium carbonate, aqueous cold total	20	b

Medium, concentration	T (°C)	Level
Potassium chlorate, aqueous cold total (7.3 %)	60	-
	20	b
	60	bb
Potassium chloride, aqueous cold total	20	b
	60	b
Potassium chromate, aqueous cold total	20	b
	60	bb
Potassium iodide, aqueous cold total	20	b
Potassium nitrate, aqueous cold total	20	b
Potassium permanganate, aqueous cold total (6.4 %)	20	b-bb
	60	-
Potassium persulphate, aqueous cold total (0.5 %)	20	b
	60	bb
Potassium sulphate, aqueous cold total	20	b
	60	b
Pine needle oil 100 %	20	u
Bone oil	20	bb
	60	u
Aqua regia	20	u
	60	u
Cresols 100 %	20	u
	60	u
Cresols, aqueous cold total (0.25 %)	20	bb-u
	60	u
Cresol solution	20	bb-u
	60	u
Copper salts, aqueous cold total	20	b
	60	b
Lanolin	20	bb
	60	u
Linseed oil	20	bb
	60	u
Lemonade	20	b
Lysol®	20	bb-u
	60	u
Magnesium salts, aqueous cold total	20	b
	60	b
Mayonnaise	20	b-bb
Methanol 100 %	20	u
	60	u
Methanol, aqueous 50 %	20	bb
	60	bb
Methylene chloride 100 %	20	u
Methylene ethyl ketone 100 %	20	u
	60	u
Lactic acid 90 %	20	bb
	60	u
50 %	20	bb
	60	u
10 %	20	b
	60	bb
Mineral oils (aromatic compound-free)	20	bb
	60	u
Furniture polish	20	u
	60	u
Motor oils (vehicles)	20	bb
	60	u
Mothballs	20	u
Nail varnish	20	u
	60	u
Nail varnish remover	20	u
	60	u
Naphthalene 100 %	20	u
	60	u
Sodium carbonate cold total	20	b
	60	-

# REHAU HEAT-SHRINK PRODUCTS

## CHEMICAL RESISTANCE OF RAU-PVC SOFT

Medium, concentration	T (°C)	Level
Sodium bisulphate, aqueous cold total	20	b
	60	-
Sodium carbonate, aqueous cold total (Soda)	20	b-bb
	60	bb
Sodium chlorate, aqueous 25 %	20	b
	60	-
Sodium chloride, aqueous cold total (cooking salt)	20	b
	60	b
Sodium chlorite, aqueous 5 %	20	b
Sodium hydroxide (caustic soda) 100 %	20	-
Sodium hypochlorite, aqueous 5 %	20	b
Sodium nitrate, aqueous cold total	20	b
Sodium perborate, aqueous cold total	20	b
	60	b-bb
Sodium phosphate, aqueous cold total	20	b
Sodium sulphate (Glauber salt) cold total	20	b
	60	-
Sodium sulphide, aqueous cold total	20	b
	60	-
Sodium sulphite, aqueous cold total	20	b
	60	-
Sodium thiosulphate, aqueous cold total (fixing salt)	20	b
	60	-
Sodium hydroxide 50 %	20	u
	60	u
25 %	20	bb
	60	bb
10 %	20	b
	60	b-bb
Nickel salts, aqueous cold total	20	b
	60	b
Nitrobenzene (nitrocellulose lacquer, dilution) 100 %	20	u
	60	u
25 %	20	bb
	60	bb-u
10 %	20	b-bb
	60	bb
Oleum	20	u
	60	u
Oil No. 3 to ASTM D 380-59 100 %	20	bb
	60	u
Oleic acid 100 %	20	u
	60	u
Oxalic acid, aqueous cold total	20	b
	60	bb
Ozone	20	b
Paraffin 100 %	20	bb
	60	u
Paraffin oil 100 %	20	bb
	60	u
Perfume	20	u
	60	u
Pectin cold total	20	b
	60	-
Petrolether 100 %	20	u
	60	u
Petroleum 100 %	20	u
	60	u
Phenol, aqueous phase cold total (approx. 9 %)	20	u
	60	u
Phenol, phenol phase cold total (approx. 70 %)	20	u
	60	u
Photographic developer, common	20	b-bb
Phosphorous pentoxide 100 %	20	b-bb
	60	-
Phosphoric acid cold total (85 %)	20	b

Medium, concentration	T (°C)	Level
	60	bb
50 %	20	b
	60	b
10 %	20	b
	60	b
Propane, aqueous 100 %	20	u
Pyridine 100 %	20	u
	60	u
Mercury 100 %	20	b
	60	-
Mercury salts, aqueous cold total	20	b
Beef dripping	20	bb
	60	u
Sagrotan	20	bb-u
	60	u
Nitric acid 50 %	20	bb-u
	60	u
25 %	20	bb
	60	bb-u
10 %	20	b-bb
	60	bb
Salt, dry	20	b
	60	b
Hydrochloric acid, conc.	20	b-bb
	60	bb
10 %	20	b
	60	b-bb
Salt water	20	b
	60	b
Lubricant, spindle oil	40	bb
	60	u
Shoe polish	20	bb
	60	u
Sulphur 100 %	20	b
	60	-
Sulphur dioxide low	20	b
	60	-
Carbon disulphide 100 %	20	u
Sulphuric acid, 96 %	20	u
	60	u
50 %	20	b-bb
	60	-
25 %	20	b
	60	bb
10 %	20	b
	60	b
Hydrogen sulphide low	20	b
	60	-
Lard	20	bb
	60	u
Sea water	20	b
	60	b
Soap - Soap solution cold total	20	b
	60	-
10 %	20	b
	60	b
Silver salts, aqueous cold total	20	b
	60	bb
Soda water	20	b
Soya oil	20	bb
	60	u
Cooking oil, vegetable	20	bb
	60	u
Cooking oil, animal	20	bb
	60	u
Starch, starch solution, aqueous	20	b

# REHAU HEAT-SHRINK PRODUCTS

## CHEMICAL RESISTANCE OF RAU-PVC SOFT

Medium, concentration	T (°C)	Level
Stearic acid 100 %	60	-
	20	b
Tar	60	bb
	20	bb
Turpentine oil	60	bb-u
	20	u
White spirit	60	u
	20	u
Tetrachloroethane 100 %	60	u
	20	u
Tetrachloroethylene 100 %	60	u
	20	u
Carbon tetrachloride 100 %	60	u
	20	u
Tetrahydrofuran 100 %	60	u
	20	u
Tetrahydronaphthalene 100 %	60	u
	20	u
Thiophen 100 %	60	u
	20	u
Ink	60	b
	20	b
Toluene 100 %	60	u
	20	u
Tomato juice	60	b
Transformer oil	60	bb
Fuels		
Regular petrol DIN	60	u
	20	u
Petrol, regular	60	u
	20	u
Petrol, super	60	u
	20	u
Engine oil	60	bb-u
Trichlorethylene	60	u
	20	u
Vaseline	60	bb
	20	bb
Water 100 %	60	b
	20	b
Water glass	60	b
Hydrogen peroxide, aqueous 30 %	60	-
10 %	60	bb
	20	bb
3 %	60	b
	20	b
Detergent, synthetic high	60	b-bb
	20	b
Ready to use	60	bb
	20	bb
Wine, mulled wine	60	b
	20	b
Acidities of wine, aqueous cold total	60	-
	20	-
Xylene 100 %	60	b
	20	b
Toothpaste	60	u
Zinc salts, aqueous cold total	60	u
	20	u
Zinn-II-chloride cold total	60	b
	20	b
Lemon juice	60	-
	20	-
Citric acid, aqueous cold total	60	b
	20	b

Medium, concentration	T (°C)	Level
Sugar, dry	60	b
	20	b
Sugar solutions	60	b
	20	b
Sugar beet molasses	60	b
	20	b
Two stroke oil	60	bb
	20	bb

### Evaluations:

- b = resistance
- bb = limited resistance
- u = not resistant
- = not tested

(\*) Source:

Plastics tables from Bodo Carlowitz

4th edition (c) 1995 by Carl Hanser publishing, Munich Pages 390-401

# REHAU HEAT-SHRINK PRODUCTS

## RAU-PVC HEAT-SHRINK SLEEVES, SMOOTH

### Delivery format:

Depending on dimensions, 25 m, 50 m or 100 m rolls

### Other:

Other dimensions/PVC types and delivery formats on request

### Colour:

Transparent, coloured transparent and covered according to the colour sample or RAL colour chart

### Note:

Heat-shrink sleeves made from PVC are not part of our standard product range.

### Measurement chart: PVC heat-shrink sleeves (mm)

Prices and delivery times on request.

Mat. No	Dim. d/s	Mat. No	Dim. d/s	Mat. No	Dim. d/s	Mat. No	Dim. d/s
1083131	1.8/0.45	1081311	5.0/1.30	1082100	9.0/0.40	1082251	15.4/1.30
1048531	2.2/0.75	1081341	5.2/0.80	1080931	9.0/1.00	1080320	16.0/0.25
1082181	2.5/0.75	1081461	5.3/0.85	1081491	9.1/0.45	1081740	16.0/0.35
1081961	2.5/1.15	1082700	5.5/0.50	1081950	9.2/1.40	1080340	16.0/0.40
1083871	2.6/0.50	1080012	5.5/1.00	1082390	9.5/0.25	1081920	16.0/0.50
1083120	2.8/0.20	1082061	5.5/1.15	1081450	10.0/0.20	1080350	16.0/0.60
1084241	2.8/0.30	1081731	5.5/1.30	1080150	10.0/0.25	1080360	16.0/0.80
1082310	2.8/0.35	1080020	6.0/0.20	1080160	10.0/0.40	1080370	16.0/1.00
1081971	2.8/1.15	1080040	6.0/0.40	1080170	10.0/0.60	1080380	16.0/1.50
1081811	2.8/1.30	1083420	6.0/0.50	1080190	10.0/1.00	1080390	16.0/2.00
1083210	3.0/0.40	1080050	6.0/0.60	1081581	10.0/1.30	1080871	16.0/3.00
1081981	3.0/1.15	1080022	6.0/1.00	1081580	10.0/1.50	1082540	17.0/0.60
1081441	3.0/1.30	1082101	6.0/1.15	1082940	12.0/0.20	1082301	18.0/0.20
1082000	3.3/0.25	1080991	6.0/1.30	1081370	12.0/0.30	1080400	18.0/0.25
1083280	3.5/0.25	1083240	6.5/0.50	1080210	12.0/0.40	1081820	18.0/0.50
1082270	3.5/0.35	1081591	6.5/1.30	1080220	12.0/0.60	1080430	18.0/0.60
1081941	3.5/1.00	1083410	7.0/0.20	1081281	12.0/1.65	1080440	18.0/0.80
1081231	3.5/1.30	1083290	7.0/0.25	1084601	12.7/0.25	1080450	18.0/1.00
1084291	4.0/0.25	1081871 <sup>1)</sup>	7.0/0.25	1081520	13.0/0.35	1080460	18.0/1.50
1081770	4.0/0.30	1084361	7.0/0.27	1082670	13.0/0.50	1082500	18.0/2.00
1082661	4.0/0.40	1082040	7.0/0.40	1081410	13.0/1.00	1082290	19.0/0.50
1082800	4.0/0.45	1082551	7.0/0.85	1082420	13.0/1.50	1083081	19.0/1.15
1082090	4.0/0.80	1080851	7.0/1.00	1082641	13.05/1.00	1080470	20.0/0.25
1082001	4.0/1.15	1081741	7.0/1.30	1080250	14.0/0.25	1080480	20.0/0.30
1081760	4.2/0.30	1084511	7.3/0.80	1080270	14.0/0.40	1080490	20.0/0.35
1083390	4.5/0.30	1084471	7.5/0.25	1080101	14.0/0.50	1080500	20.0/0.40
1080831	4.5/0.45	1084561	7.5/0.40	1080280	14.0/0.60	1081250	20.0/0.50
1082141	4.5/1.15	1083160	7.5/0.50	1080300	14.0/1.00	1080520	20.0/0.80
1081221	4.5/1.30	1082020	8.0/0.20	1083161	14.0/1.40	1080530	20.0/0.90
1080821	4.8/0.60	1080100	8.0/0.25	1080310	14.0/1.50	1080540	20.0/1.00
1083090	5.0/0.20	1081990	8.0/0.40	1080761	15.0/0.50	1082021 <sup>2)</sup>	20.0/1.50
1083150	5.0/0.25	1080120	8.0/0.50	1082271	15.0/0.60	1081780	20.0/2.00
1082260	5.0/0.35	1081721	8.0/0.90	1082740	15.0/1.00	1081851 <sup>2)</sup>	20.0/2.00
1083220	5.0/0.50	1080140	8.0/1.00	1081081	15.0/1.10	1081781	21.0/1.50
1084491	5.0/0.80	1081161	8.0/1.30	1081870	15.0/1.30	1080351	21.0/2.20
1082080	5.0/1.00	1080141	9.0/0.20	1081291	15.0/1.65	1082010	22.0/0.25
1082161	5.0/1.15	1081280	9.0/0.25	1082510	15.0/2.00	1080560	22.0/0.50



# REHAU HEAT-SHRINK PRODUCTS

## RAU-PVC HEAT-SHRINK SLEEVES, SMOOTH



d: Nominal diameter (according to the object to be covered)

s: Wall thickness at nominal diameter d

Mat. No	Dim. d/s
1081620	22.0/0.55
1080570	22.0/0.80
1080580	22.0/1.00
1082081 <sup>2)</sup>	22.0/1.25
1080590	22.0/1.50
1080081	23.0/0.30
1081480	24.0/0.40
1080600	24.0/0.60
1080610	24.0/0.80
1080620	24.0/1.00
1080630	24.0/1.50
1080650	25.0/0.25
1080680	25.0/0.40
1082250	25.0/0.50
1082630	25.0/2.50
1080552	25.5/1.00
1080690	26.0/0.80
1080700	26.0/1.00
1080710	26.0/1.50
1082780	27.0/0.25
1080151	27.0/0.50
1083300	28.0/0.35
1080730	28.0/0.80
1080740	28.0/1.00
1082091 <sup>2)</sup>	28.0/1.00
1082430	28.0/1.20
1082671	28.05/1.00
1081310	30.0/0.25
1080770	30.0/0.35
1082120	30.0/0.40
1080790	30.0/1.00
1080780	30.0/0.80
1080800	30.0/1.50
1081420	30.0/2.50
1081530	32.0/0.30
1082300	32.0/0.60
1080830	32.0/1.00

Mat. No	Dim. d/s
1080840	32.0/1.50
1081551	32.0/1.65
1080981	33.0/1.60
1083320	34.0/0.60
1080870	34.0/1.00
1080880	34.0/1.50
1080890	34.0/2.00
1082311	34.5/0.20
1080901	35.0/0.30
1082160	35.0/0.40
1082070	35.0/0.50
1082401	35.0/0.80
1080930	36.0/1.00
1082110	38.0/0.40
1082590	38.0/0.70
1080970	38.0/1.00
1080980	38.0/1.50
1082830	40.0/0.35
1081000	40.0/0.60
1081010	40.0/1.00
1081020	40.0/1.50
1081030	40.0/2.00
1080532	42.0/1.00
1081300	42.0/1.50
1083321	43.0/0.70
1082920	45.0/0.50
1081040	45.0/0.60
1081050	45.0/1.00
1081861 <sup>2)</sup>	45.0/2.00
1081060	45.0/1.50
1081070	45.0/2.00
1083100	45.0/3.00
1080021	46.0/0.60
1082880	48.0/2.50
1080041	50.0/0.40
1081080	50.0/0.55
1081100	50.0/1.00

Mat. No	Dim. d/s
1081110	50.0/1.50
1083260	51.0/0.60
1083040	53.0/3.00
1081140	55.0/1.00
1081150	55.0/1.50
1080121	55.0/2.50
1080131	58.0/0.80
1081880	60.0/0.60
1081180	60.0/1.00
1081190	60.0/1.50
1081200	60.0/2.00
1082970	60.0/3.00
1083350	63.0/0.50
1083500	63.0/0.80
1082990	65.0/0.50
1083470	65.0/1.00
1081371	68.0/2.20
1082201	70.0/0.45
1083070	70.0/0.75
1082240	70.0/1.00
1081210	70.0/1.50
1082870	74.0/3.00
1083360	75.0/0.60
1081890	75.0/0.65
1081840	75.0/1.00
1081610	75.0/1.50
1083230	75.0/2.00
1083270	76.0/0.60
1082701	80.0/0.45
1081940	80.0/0.65
1080771	80.0/1.30
1081220	80.0/1.50
1082520	80.0/1.80
1082180	80.0/2.00
1081991	85.0/0.80
1081230	90.0/0.60
1081690	90.0/1.00

Mat. No	Dim. d/s
1081510	90.0/2.00
1082580	100.0/1.00
1082211	100.0/1.20
1082600	100.0/1.50
1082850	105.0/0.80
1083050	120.0/1.50
1082900	130.0/1.40
1080011	130.0/2.50
1080152	140.0/1.00
1080702	180.0/1.10
1080852	210.0/1.10

<sup>1)</sup> Delivered filled with air

<sup>2)</sup> Brushed interior, surface depth 0.00 - 0.20 mm

# REHAU HEAT-SHRINK PRODUCTS

## RAU-PVC HEAT-SHRINK SLEEVES, RIBBED

### Delivery format:

Depending on dimensions, 25 m, 50 m or 100 m rolls

### Other:

Other dimensions/PVC types, rib designs and delivery formats on request

### Colour:

















Transparent, coloured transparent and covered according to the colour sample or RAL colour chart

















### Note:

Heat-shrink sleeves made from PVC are not part of our standard product range.

Prices and delivery times on request.

### Measurement chart PVC heat-shrink sleeves (mm):

Mat. No	d/s/S	Ribs	No. ribs
1085020	6/0.6/0.8		24
1085040	10/0.6/0.8		27
1085110	12/0.6/1.2		12
1085080	13/0.6/3.3		9
1085210	14/0.8/1.2		20
1085240	16/0.5/0.7		16
1086360	16/1.8/2		39
1086810	17/0.65/1.5		27
1085800	17/0.8/1.4		24
1085320	18/0.6/1		24
1085330	18/1/1.3		24
1086760	18/1.2/1.4		36
1085340	19/0.5/0.8		46
1085270	19/1.5/2		20
1085180	19/2/3.5		12
1085370	20/0.6/0.9		16
1085380	20/0.8/1		40

Mat. No	d/s/S	Ribs	No. ribs
1085430	20/1.5/1.7		40
1085420	20/3/3.2		26
1086800	22/0.65/1.5		33
1086780	22/0.7/1.0		28
1086650	22/0.8/1		39
1085970	22/1/1.2		30
1085440	22/1/1.45		18
1086190	22/1.5/1.9		18
1085410	22/1.9/2.5		24
1085470	24/1.2/1.4		45
1085480	25/0.8/1		45
1085500	25/1/1.4		26
1085510	25/1.6/1.8		18
1085560	27/0.8/1		45
1085810	27/1.3/2.9		12
1085580	28/1/1.3		26
1086750	30/0.55/0.85		48

# REHAU HEAT-SHRINK PRODUCTS

## RAU-PVC HEAT-SHRINK SLEEVES, RIBBED

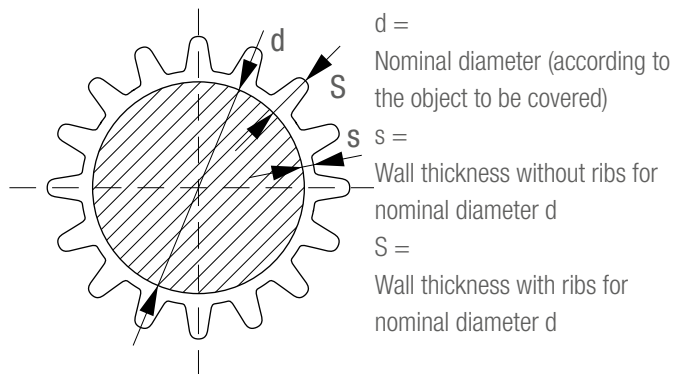

Mat. No	d/s/S	Ribs	No. ribs
<b>1</b> 086820	30/0.65/1.5		40
<b>1</b> 085600	30/1/1.2		48
<b>1</b> 086700	30/1.2/1.7		24
<b>1</b> 085620	30/1.5/1.9		48
<b>1</b> 085640	30/2.1/2.4		36
<b>1</b> 085650	30/2.5/2.8		36
<b>1</b> 086680	32/0.6/1		19
<b>1</b> 086710	32/1/1.4		19
<b>1</b> 086550*	32/1/1.5		
<b>1</b> 085820	33/1.5/3.4		12
<b>1</b> 086470	34/0.7/1		12
<b>1</b> 086310	34/0.8/1.1		48
<b>1</b> 086340	34/1.7/2		34
<b>1</b> 086790	34/2.3/2.5		96
<b>1</b> 086320	35/0.5/0.8		48
<b>1</b> 086500	35.5/0.8/1.3		23
<b>1</b> 086060	38/0.7/1		64

Mat. No	d/s/S	Ribs	No. ribs
<b>1</b> 085660	38/1.9/4.2		12
<b>1</b> 086480	40/1/1.7		23
<b>1</b> 085700	40/1.1/1.3		64
<b>1</b> 085680	40/1.7/2.1		36
<b>1</b> 085690	42/1.6/1.9		36
<b>1</b> 085710	43/1.3/1.8		36
<b>1</b> 086010	45/1/1.2		120
<b>1</b> 085720	45/1.2/1.6		36
<b>1</b> 086220	48/1.5/1.7		120
<b>1</b> 085890	48/1.5/3		20
<b>1</b> 085730	50/1/1.2		120
<b>1</b> 085740	60/1/1.25		140
<b>1</b> 086390	60/1.5/1.75		140
<b>1</b> 086660	90/2/2.7		112

\* irregular rib arrangement

# REHAU HEAT-SHRINK PRODUCTS

ENQUIRY CHECKLIST REHAU HEAT-SHRINK SLEEVES

YOUR ENQUIRY MADE EASY:

---



# REHAU HEAT-SHRINK PRODUCTS

## ENQUIRY CHECKLIST FOR REHAU RAUCROSS HEAT-SHRINK SLEEVES

### YOUR ENQUIRY MADE EASY:

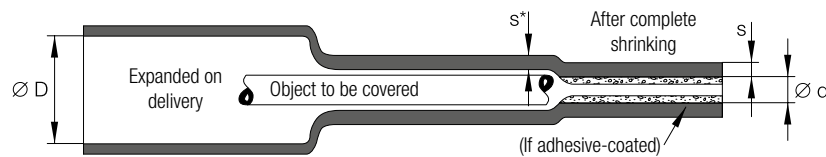

#### Information about the heat-shrink sleeve

D: Internal diameter min. on delivery

d: Internal diameter max. following complete shrinking

s: Wall thickness following complete shrinking

The wall thickness of the partially-shrunk sleeve  $s^*$  (on the object) can be calculated roughly using the following formula:

$$d \times s$$

---

**Object diameter**

#### Dimensions:

\_\_\_\_\_ (Internal diameter (D))      \_\_\_\_\_ mm (Internal diameter (d))      \_\_\_\_\_ mm (Wall thickness (s))

#### or:

the external diameter of the object to be covered:

min: \_\_\_\_\_ mm      max: \_\_\_\_\_ mm

**Target wall thickness ( $s^*$ )** of the sleeve on the object: \_\_\_\_\_ mm

**Application temperature:** \_\_\_\_\_ °C

**Flame-retardant quality:**       yes       no

**Colour:**       black       \_\_\_\_\_

Sleeve with interior **adhesive coating**       yes       no

**Intended application** (brief description, sketch, sample):

**Product currently used:** \_\_\_\_\_

**Annual requirement:** \_\_\_\_\_ **Target price:** \_\_\_\_\_

**Comments** (e.g. notes about processing, special requirements, etc.)

\_\_\_\_\_

\_\_\_\_\_

**Date:**

**Enquiry made by:**

# REHAU HEAT-SHRINK PRODUCTS

## ENQUIRY CHECKLIST REHAU HEAT-SHRINK SLEEVES

MADE FROM RAU-PVC SOFT / YOUR ENQUIRY MADE EASY:



### Information about the heat-shrink sleeve

d: Nominal diameter (according to the object to be covered)

s: Wall thickness at nominal diameter d

### Dimensions:

\_\_\_\_\_ mm (Internal diameter (d))      \_\_\_\_\_ mm (Wall thickness (s))

Description of the object: Round bar, pipe made from \_\_\_\_\_

with diameter \_\_\_\_\_

Other shape \_\_\_\_\_

Application temperature: \_\_\_\_\_ °C

Flame-retardant quality:       yes       no

Colour:       black       \_\_\_\_\_

Intended application (brief description, sketch, sample):

Product currently used: \_\_\_\_\_

Annual requirement: \_\_\_\_\_ Target price: \_\_\_\_\_

Comments (e.g. notes about processing, special requirements, etc.)

\_\_\_\_\_

Date: \_\_\_\_\_ Enquiry no.: \_\_\_\_\_ Enquiry made by: \_\_\_\_\_

**Notes:**

A series of 25 horizontal grey bars, each approximately 20 pixels high, spanning the width of the page. These bars are intended for handwritten notes.

# SO THAT WE STAY IN TOUCH

## INVITATION TO CONTACT US

Do you require any further information or do you have questions about our range of products? Then take advantage of one of the various ways of contacting us:

### Sales offices

Our staff in the REHAU sales offices will be happy to provide you with advice and support. Please find your local REHAU office in the list below.

### Internet

You can of course also find our wide range of products on the internet. You will also be able to obtain an overview of our comprehensive range of services. Visit us at: [www.rehau.com](http://www.rehau.com)

### The customer portal

The REHAU customer portal offers a range of functions that are available to you 365 days a year, 24 hours a day. In the password-protected area, you have the option to place orders directly for each article selected or even "upload" orders from your own merchandise management system and track the status of your orders. The pricing information saved here may also be conveniently prepared as a price list and printed out. We have put together data sheets and downloads for you in the information area.

The customer portal is accessed directly via the internet site for your country.

This document is protected by copyright. All rights based on this are reserved. No part of this publication may be translated, reproduced or transmitted in any form or by any similar means, electronic or mechanical, photocopying, recording or otherwise, or stored in a data retrieval system.

Our verbal and written advice relating to technical applications is based on experience and is to the best of our knowledge correct but is given without obligation.

The use of REHAU products in conditions that are beyond our control or for applications other than those specified releases us from any obligation in regard to claims made in respect of the products.

We recommend that the suitability of any REHAU product for the intended application should be checked. Utilization and processing of our products are beyond our control and are therefore exclusively your responsibility. In the event that a liability is nevertheless considered, any compensation will be limited to the value of the goods supplied by us and used by you.

Our warranty assumes consistent quality of our products in accordance with our specification and in accordance with our general conditions of sale.

### REHAU SALES OFFICES

**AE: Middle East**, Phone: +9714 8835677, [dubai@rehau.com](mailto:dubai@rehau.com) **AU: Adelaide**, Phone: +61 8 82990031, [adelaide@rehau.com](mailto:adelaide@rehau.com) **Brisbane**, Phone: +61 7 55271833, [brisbane@rehau.com](mailto:brisbane@rehau.com) **Melbourne**, Phone: +61 3 95875544, [melbourne@rehau.com](mailto:melbourne@rehau.com) **Perth**, Phone: +61 8 94564311, [perth@rehau.com](mailto:perth@rehau.com) **Sydney**, Phone: +61 2 87414500, [sydney@rehau.com](mailto:sydney@rehau.com) **CA: Moncton**, Phone: +1 506 5382346, [moncton@rehau.com](mailto:moncton@rehau.com) **Montreal**, Phone: +1 514 9050345, [montreal@rehau.com](mailto:montreal@rehau.com) **St. John's**, Phone: +1 709 7473909, [stjohns@rehau.com](mailto:stjohns@rehau.com) **Toronto**, Phone: +1 905 3353284, [toronto@rehau.com](mailto:toronto@rehau.com) **Vancouver**, Phone: +1 604 6264666, [vancouver@rehau.com](mailto:vancouver@rehau.com) **GB: Glasgow**, Phone: +44 1698 503-700, [glasgow@rehau.com](mailto:glasgow@rehau.com) **Manchester**, Phone: +44 161 7777-400, [manchester@rehau.com](mailto:manchester@rehau.com) **Slough**, Phone: +44 1753 5885-00, [slough@rehau.com](mailto:slough@rehau.com) **IE: Dublin**, Phone: +353 1 816502-0, [dublin@rehau.com](mailto:dublin@rehau.com) **NZ: Auckland**, Phone: +649 2722264, [auckland@rehau.com](mailto:auckland@rehau.com) **SG: Singapore**, Phone: +65 63926006, [singapore@rehau.com](mailto:singapore@rehau.com) **US: Detroit**, Phone: +1 248 8489100, [detroit@rehau.com](mailto:detroit@rehau.com) **Grand Rapids**, Phone: +1 616 2856867, [grandrapids@rehau.com](mailto:grandrapids@rehau.com) **Los Angeles**, Phone: +1 951 5499017, [losangeles@rehau.com](mailto:losangeles@rehau.com) **Minneapolis**, Phone: +1 612 253 0576, [minneapolis@rehau.com](mailto:minneapolis@rehau.com) **ZA: Durban**, Phone: +27 31 657447, [durban@rehau.com](mailto:durban@rehau.com), **Johannesburg**, Phone: +27 11 2011300, [johannesburg@rehau.com](mailto:johannesburg@rehau.com)